



Prolift SCLTM

STANDARD COMMERCIAL LIFT

Planning Guide

Roped Hydraulic Commercial Wheelchair Lift

Applicable Codes:

ASME A18.1-1999, A18.1a-2001, A18.1b-2001,
A18.1-2003, A18.1-2005, and A18.1-2008 Section 2
CAN/CSA B355 - M00

Part No. 000754
03-m05-2010

© 2010 Savaria Corporation

Table of Contents

GENERAL	3
PRODUCT DESCRIPTION	4
PROLIFT SCL STANDARD COMMERCIAL LIFT SPECIFICATIONS	5
CAB TYPE SELECTION SHEET	6
MACHINE ROOM OPTIONS	7
CONTROLLER TANK SPECIFICATIONS	8
PROLIFT SCL 35" X 48" TYPE 1 LEFT HAND – ENTER/EXIT SAME SIDE	9
PROLIFT SCL 35" X 54" TYPE 1 LEFT HAND – ENTER/EXIT SAME SIDE	10
PROLIFT SCL 35" X 60" TYPE 1 LEFT HAND – ENTER/EXIT SAME SIDE	11
PROLIFT SCL 35" X 48" TYPE 2 WALK THROUGH – ENTER/EXIT EITHER SIDE	12
PROLIFT SCL 35" X 54" TYPE 2 WALK THROUGH – ENTER/EXIT EITHER SIDE	13
PROLIFT SCL 35" X 60" TYPE 2 WALK THROUGH – ENTER/EXIT EITHER SIDE	14
PROLIFT SCL 35" X 48" TYPE 3 OR 4 - ENTER/EXIT FRONT OR SIDE	15
PROLIFT SCL 35" X 54" TYPE 3 OR 4 - ENTER/EXIT FRONT OR SIDE	16
PROLIFT SCL 35" X 60" TYPE 3 OR 4 - ENTER/EXIT FRONT OR SIDE	17
PRO AUTO AND PRO MANUAL DOOR SPECIFICATIONS	18
LOADS ON BUILDING	19
MASONRY CONSTRUCTION - SECTIONAL VIEW	20
MASONRY CONSTRUCTION - PLAN VIEW	21
WOOD CONSTRUCTION - SECTIONAL VIEW	22
WOOD CONSTRUCTION - PLAN VIEW	23
PIT DETAILS	24
OVERHEAD CLEARANCE DETAILS	25
SUGGESTED WALL CONFIGURATION FOR WOOD CONSTRUCTION	26
SUGGESTED WALL CONFIGURATION FOR WOOD CONSTRUCTION	27
RAIL SUPPORT WALL SPECIFICATIONS	28
PROLIFT SCL STANDARD NOTES	29
SPECIFICATIONS FOR PART 5.3 COMPLIANCE	30

General

This planning guide is designed to assist architects, contractors and lift professionals in planning for a Prolift SCL Commercial Wheelchair Lift to meet the requirements of ASME A18.1-1999, A18.1a-2001, A18.1b-2001, A18.1-2003, A18.1-2005, A18.1-2008 Section 2, and CAN/CSA B355 M00. We strongly recommend that you contact the code authority having jurisdiction in the area(s) where the lift will be installed to become familiar with all the legal requirements governing the installation and use of lifts in commercial applications. It is extremely important for you to know and adhere to all regulations pertaining to the installation and use of lifts.

IMPORTANT NOTICE

This Planning Guide provides nominal dimensions and specifications useful for the initial planning of an lift project. Before beginning actual construction, be sure to receive application drawings customized with specifications and dimensions for your specific project.

Lift configurations and dimensions are in accordance with our interpretation of the standards set forth by ASME A18.1-1999, A18.1a-2001, A18.1b-2001, A18.1-2003, A18.1-2005, A18.1-2008 Section 2, and CAN/CSA B355 M00. Please consult Savaria or the authorized Savaria dealer in your area for more specific information pertaining to your project, including any discrepancy between referenced standards and those of any local codes or laws.

The dimensions and specifications in this Planning Guide are subject to change (without notice) due to product enhancements and continually evolving codes and product applications.

- Determine customer's intention for use.
- Determine code requirements of site.
- Determine installation parameters of site.
- Use page 6 to determine the car type and hoistway size requirements.
- Use pages 7 and 29 to plan for machine room and electrical requirements.

Product Description

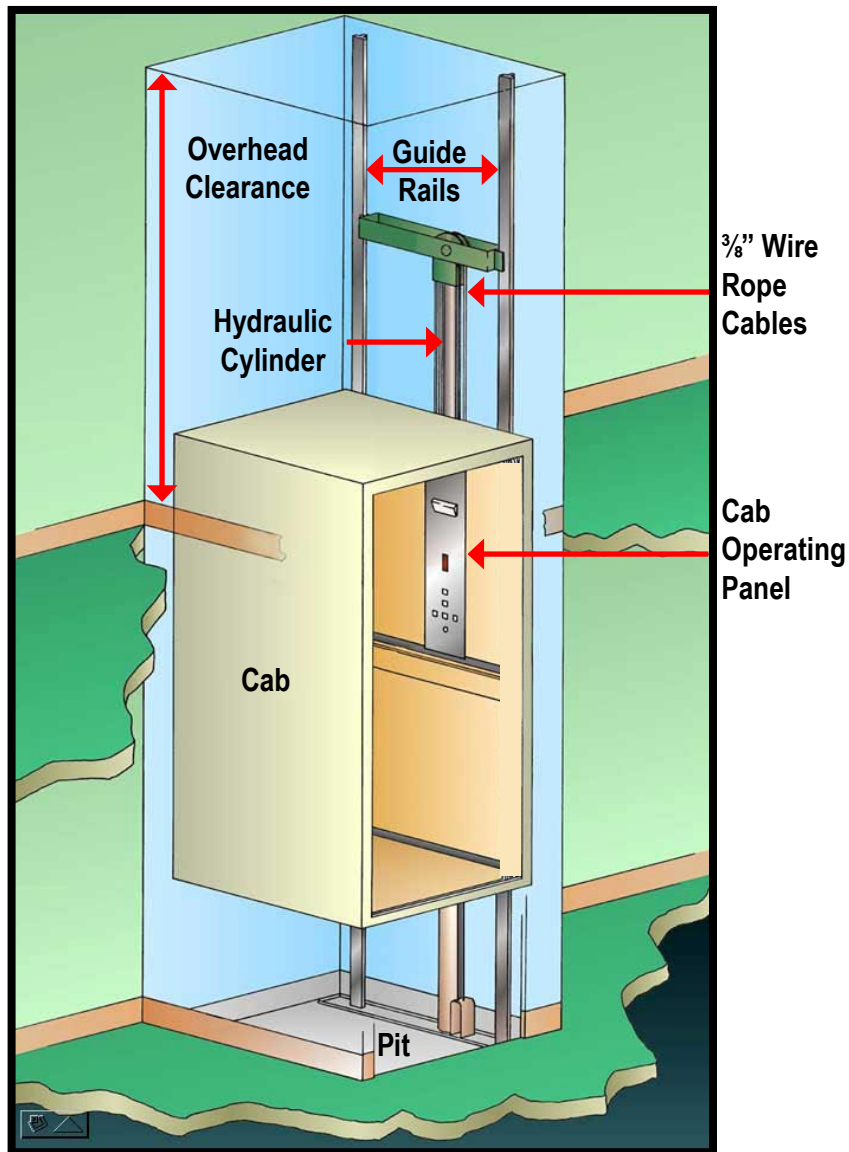

Prolift SCL in Hoistway

Meets (ADA) Americans with Disabilities Act Requirements

The Prolift SCL meet the requirements of the ADA Accessibility Guidelines as a means to provide public building access.

Design Assistance

With over 30 years of experience, Savaria has the expertise to provide solutions to practically every design challenge you face. Please call our Customer Service Department for professional advice at (800) 661-5112 or (905) 791-5555.

Prolift SCL Standard Commercial Lift Specifications

Load Capacity	750 lb (340 kg), 1000 lb (454 kg)
Rated Speed	30 fpm (.15 mps)
Power Supply (circuit to be supplied by others)	208 volt, three phase, 60 Hz, 30 amps or 230 volt, single phase, 60 Hz, 40 amps
Lighting Supply (circuit to be supplied by others)	115 volt, 60 cycle, 15 amps
Drive System	1:2 Cable Hydraulic with Slack Cable Safety Device 3 hp 24 Volt DC submersed motor Two 3/8" diameter steel aircraft cables Rope wedge sockets
Cab Size	W35" x L48" x H80" (889 mm x 1219 mm x 2032 mm), Type 1, 2, 3, 4 W35" x L54" x H80" (889 mm x 1371 mm x 2032 mm), Type 1, 2, 3, 4 W35" x L60" x H80" (889 mm x 1524 mm x 2032 mm), Type 1, 2, 3, 4
Cab Panel Finish	Standard Solid Melamine or MDF Panels (standard), Unfinished Oak Veneer Panels (optional), Plastic Laminate Panels (optional)
Maximum Travel	23 feet (7000 mm), USA max. 12 feet (3650 mm)
Control System	Constant Pressure User Interface Solid State Electronics with Relay Logic Motor Controls
Levels and Openings	5 Stops and 2 Openings
Pit Depth Required	8" (203 mm) minimum up to 36" (914 mm)
Minimum Overhead Clearance	92" (2337 mm)
Hall Station and Control Panel Finish	Stainless Steel
Standard Features	<ul style="list-style-type: none"> Anti-Creep Device Automatic Cab ON/OFF Lighting Car Top Stop Switch Clear Anodized Aluminum Cab Trim Data Plates, Capacity Tags and Rope Tags Emergency Stop and Alarm Buttons Emergency Battery Back-up for Lighting, Alarm and Emergency Lowering Upper and Lower Terminal Limits Limited Warranty covers the repair or replacement of any defective parts for a period of 36 months from date of shipment Magnetic Floor Selection, Stopping and Re-leveling Manual Reset Slack Rope Safety Switch Mechanical Rail Shoring Blocks Negative Pressure Switch Pit Switch Presentation Drawings Pump Run Timer Rail Sections (8 ft optional or 16 ft standard) Recessed Incadescent Down Lights Stainless Steel Handrail Two 12 V, 4 AH, Sealed No Maintenance Batteries with 24 V, 4 amp Smart Charge™ Battery Charge Unfinished Plywood Sub-Floor Variable Speed Pressure Compensated Valve with Manual Lowering White Egg Crate Ceiling
Options	<ul style="list-style-type: none"> Cab Floor Rubber Mat Emergency Hands-Free Telephone Hose with Flow Control Valve (15 ft, 20 ft or 25 ft) In Car Digital Floor Indicator Interlocks for Doors by Others (Kwiklock or GAL) Keyed ON/OFF Control Panel and Hall Stations Lamp Style Hall Position Indicators Light Screens Pipe Rupture Valve Pro Manual or Pro Auto Fire Rated Door with Prolocks Spring Buffers (24" Pit Depth Minimum)

Cab Type Selection Sheet

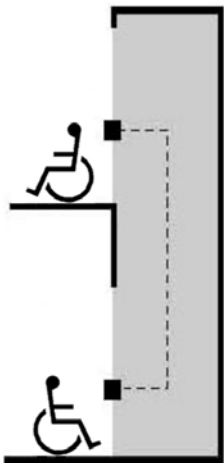
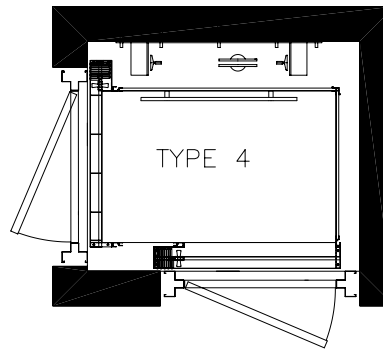
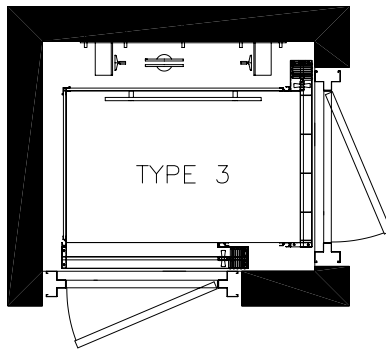
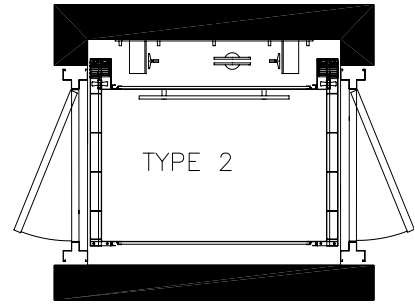
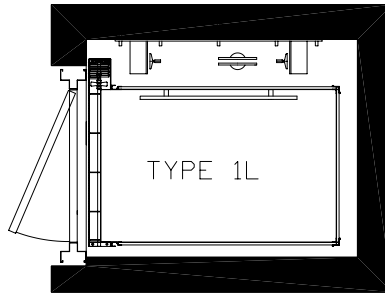
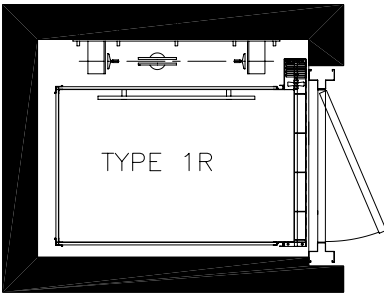

Type 1

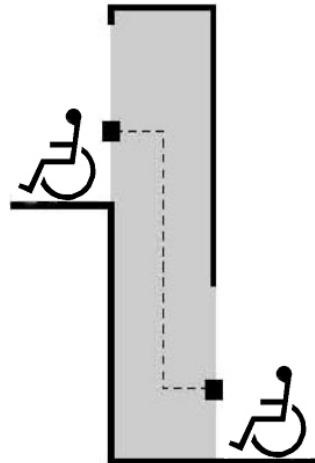

Type 2

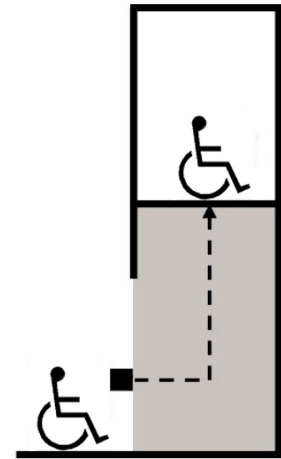

Type 3 and 4

IMPORTANT

Finished hoistway dimensions must include the drywall. Determine the fire rating of the hoistway, the type and layers of sheet rock and build only off the final shop drawings specific to your project.

Machine Room Options

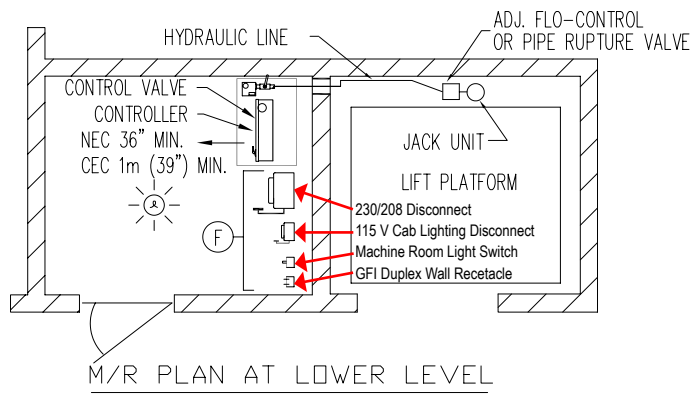

Left Hand Position

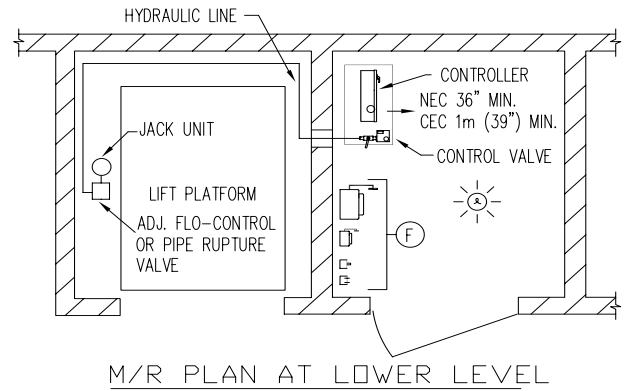

Right Hand Position

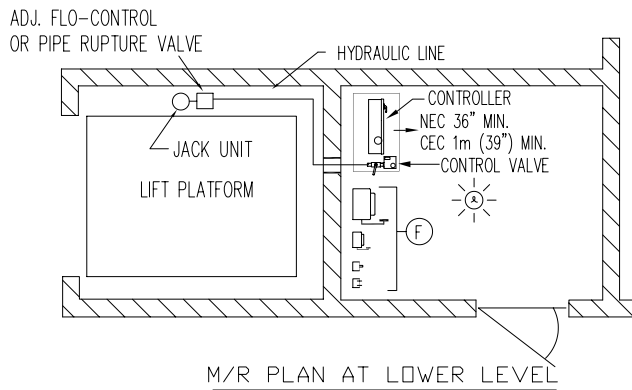

Back Position

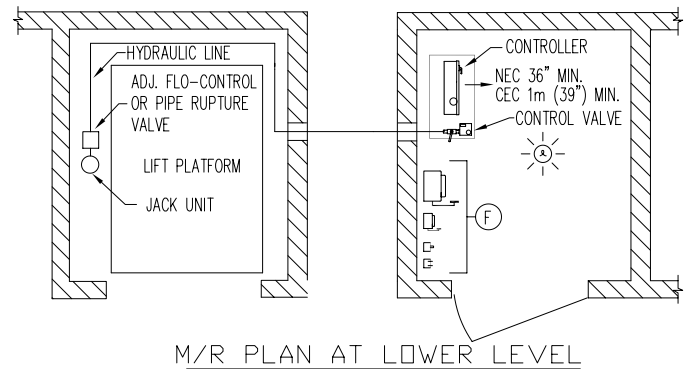

Remote Position

- The machine room must be built in accordance with local, state/provincial and national codes. Adequate ventilation is required to maintain a temperature of 50°F to 100°F for output of 3600 BTU per hour.
- Power supply must be 208V 3ph with 30 amp OR 230V 1ph with 40 amp dedicated circuit with equipment ground. A lockable fused disconnect with an auxiliary normally open interlock switch must be located next to the controller. The electrical circuit must terminate on the line side terminal lugs of the disconnect. It is provided and installed by others.
- The machine room lighting shall be a minimum of 19 foot candles at working surfaces.
- The switch for the light must be within 18" of the strike side of the machine room door.
- The switch, light and wiring are provided and installed by others. The light must be guarded to prevent accidental breakage of contact with the hot bulb. The switch, light, wiring and guard are provided and installed by others.
- A convenience outlet for the cab lights of 115V 1ph 15 amp single phase with G.F.I. shall be located next to the light switch in the machine room, provided and installed by others. NEC requires a 30" wide x 36" deep work space in front of the disconnects and the lift controller.
- A telephone line circuit is to be provided and installed by others. This circuit must be connected to an outside line or a 24 hour central exchange.
- The machine room access door must be self closing, self locking with a key and spring return latch. Door and hardware are provided and installed by others. Consult local building codes for door construction.
- The machine room must be free of any pipes, wiring and obstructions not related to the operation of the lift. Provide a 4 inch conduit from the lift shaft to the remote machine room.

Controller Tank Specifications

Dimensions (inches)	H 47" x W 28" x D 17" (Relay Brd) H 57" x W 28" x D 17" (PLC - 5 stop option only)
Minimum Required Clearance in Front (inches)	39"
Valve and Manual Lowering Handle Location	Inside Tank
Rupture Valve Test	T-fitting factory installed
Tank to Controller Wiring	Quick connect valve and motor wiring
Controller Layout	PLC or Relay Board
Keyed Lock to Tank	Yes
Machine Room Required	No (with local jurisdiction approval)
Tank Capacity (gal/ltr)	15-16.5 gal/57-63 ltr
Max. Dry Weight (lbs/kgs)	147 lbs/55 kg
Max. Filled Weight (lbs/kgs)	312 lbs/117 kg
Operating Environment	50°F - 120°F /10°C - 49°C
Operating Volume	57 dBA

Controller Tank Features

- Hydraulic Hose Connection Ports on either side of the tank
- Built in handles on either side of the tank
- Isolation mounting of pump motor valve assembly minimizes operating noise

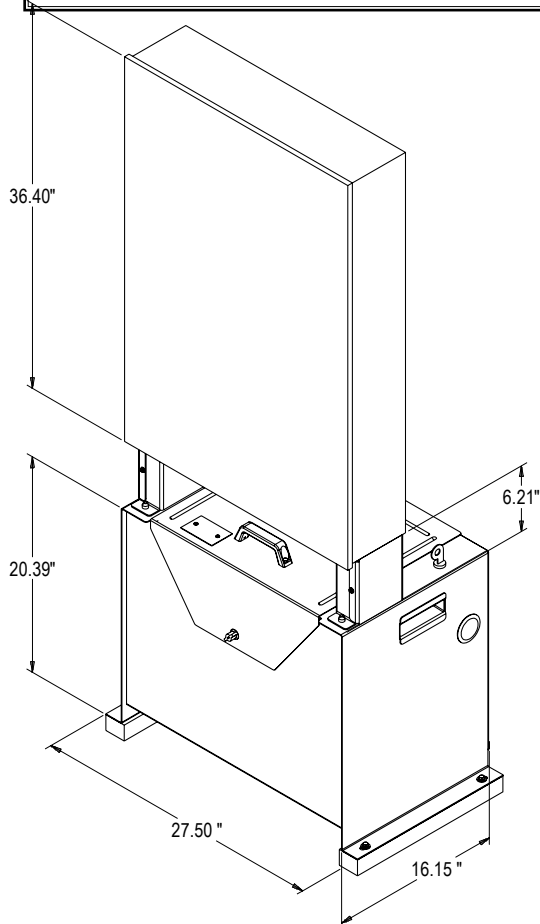

PLC Controller Tank

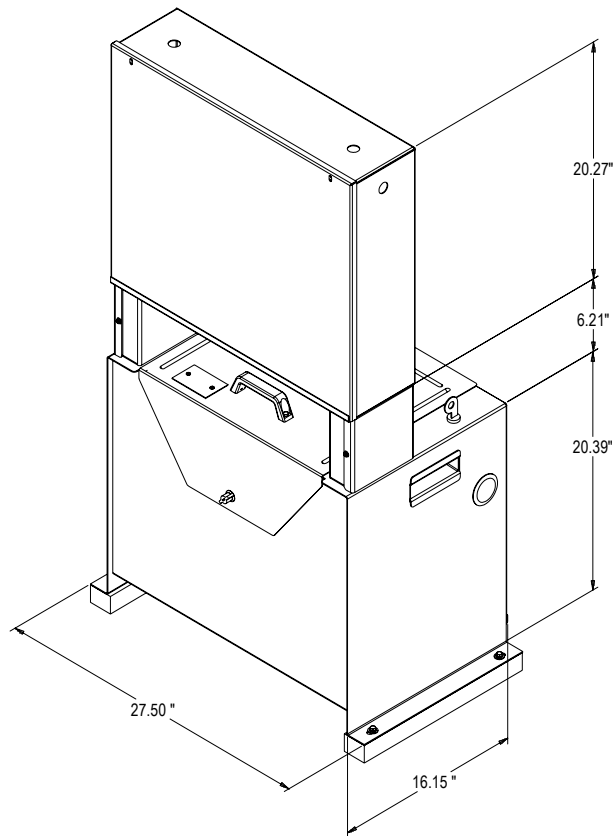

Relay Board Controller Tank

PROLIFT SCL 35" X 48" TYPE 1 LEFT HAND – ENTER/EXIT SAME SIDE

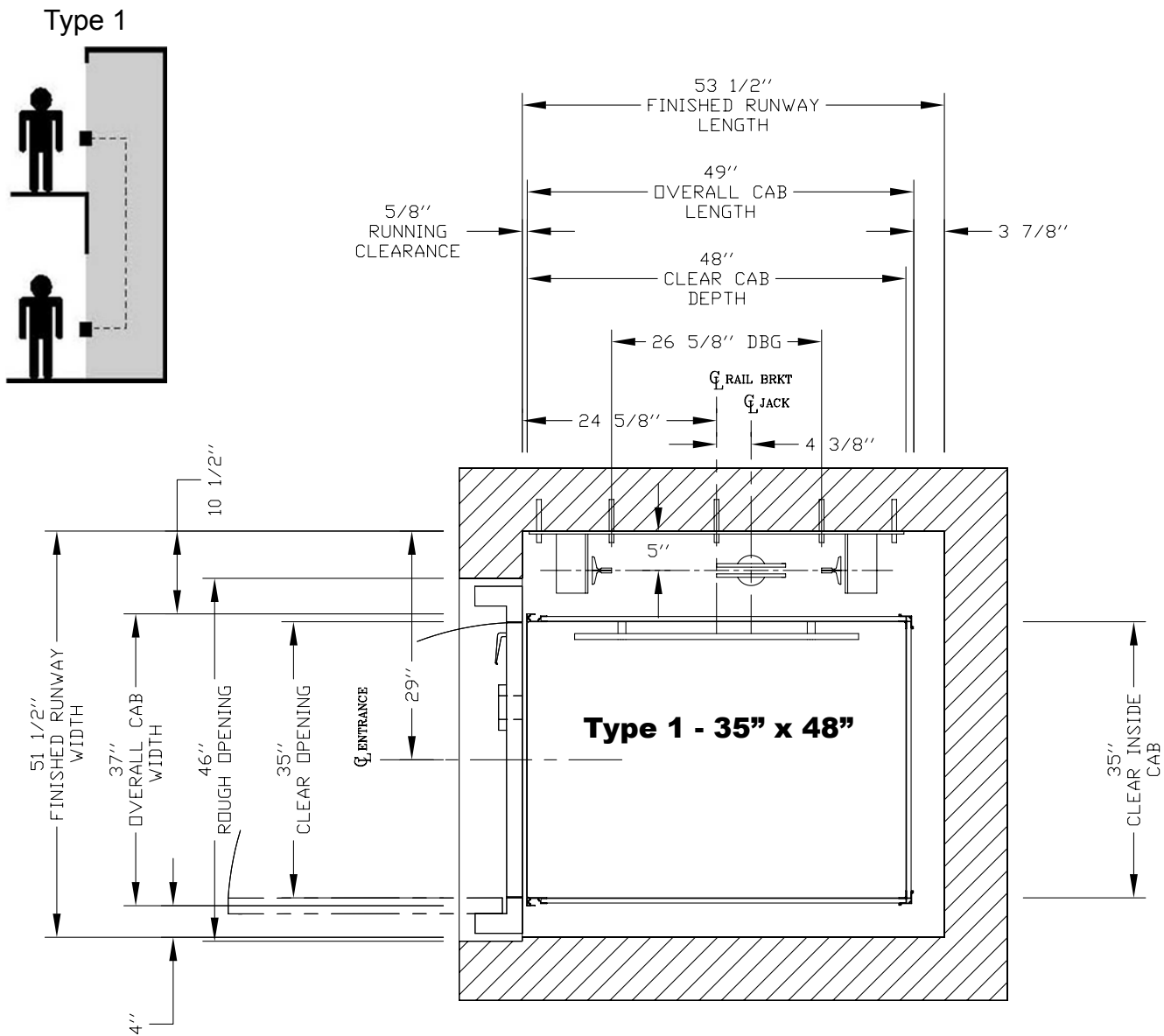

NOTE

Plan view drawing can be reversed for Right Hand applications.

PROLIFT SCL 35" X 54" TYPE 1 LEFT HAND – ENTER/EXIT SAME SIDE

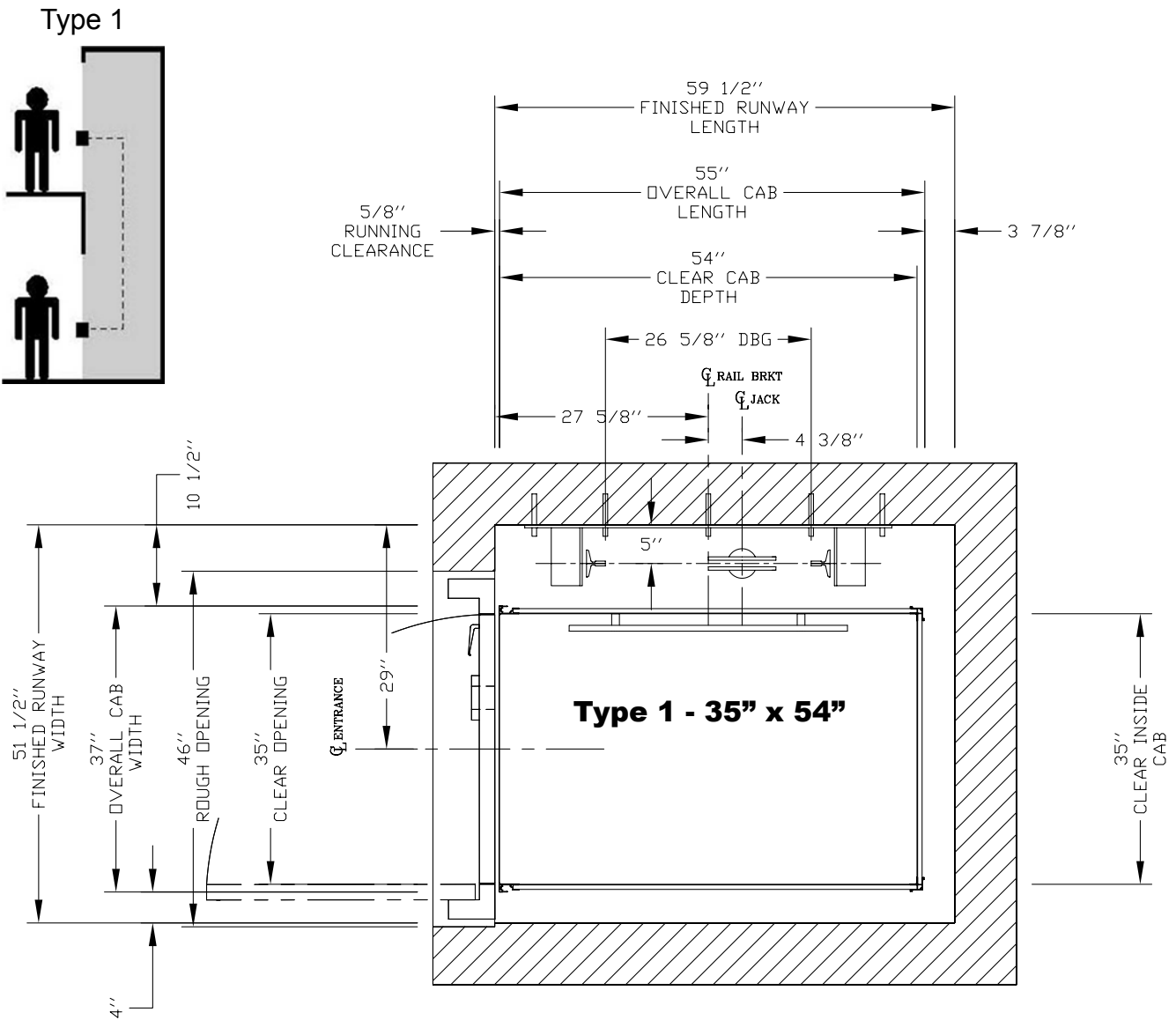

NOTE

Plan view drawing can be reversed for Right Hand applications.

PROLIFT SCL 35" X 60" TYPE 1 LEFT HAND – ENTER/EXIT SAME SIDE

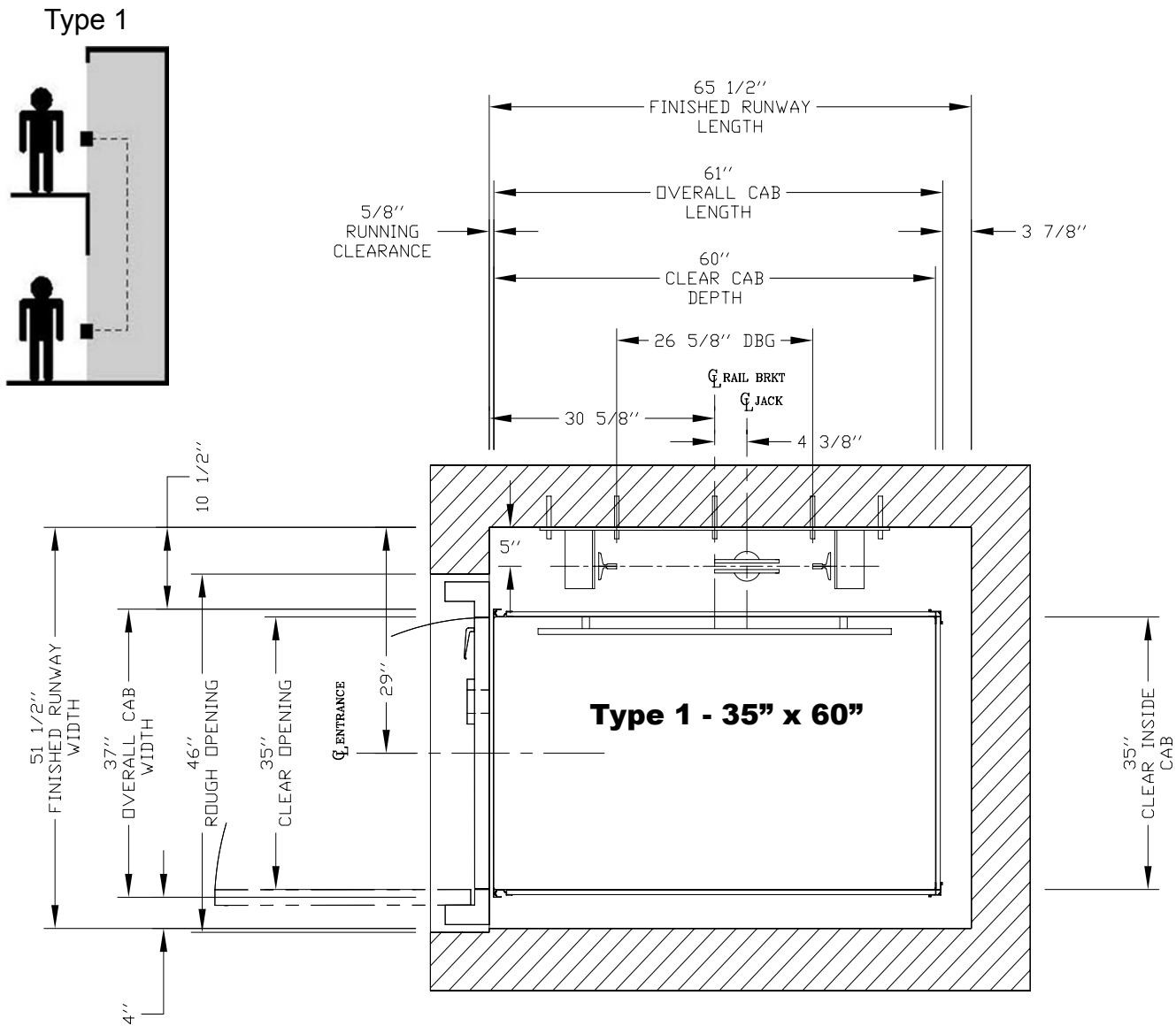

NOTE

Plan view drawing can be reversed for Right Hand applications.

PROLIFT SCL 35" X 48" TYPE 2 WALK THROUGH – ENTER/EXIT EITHER SIDE

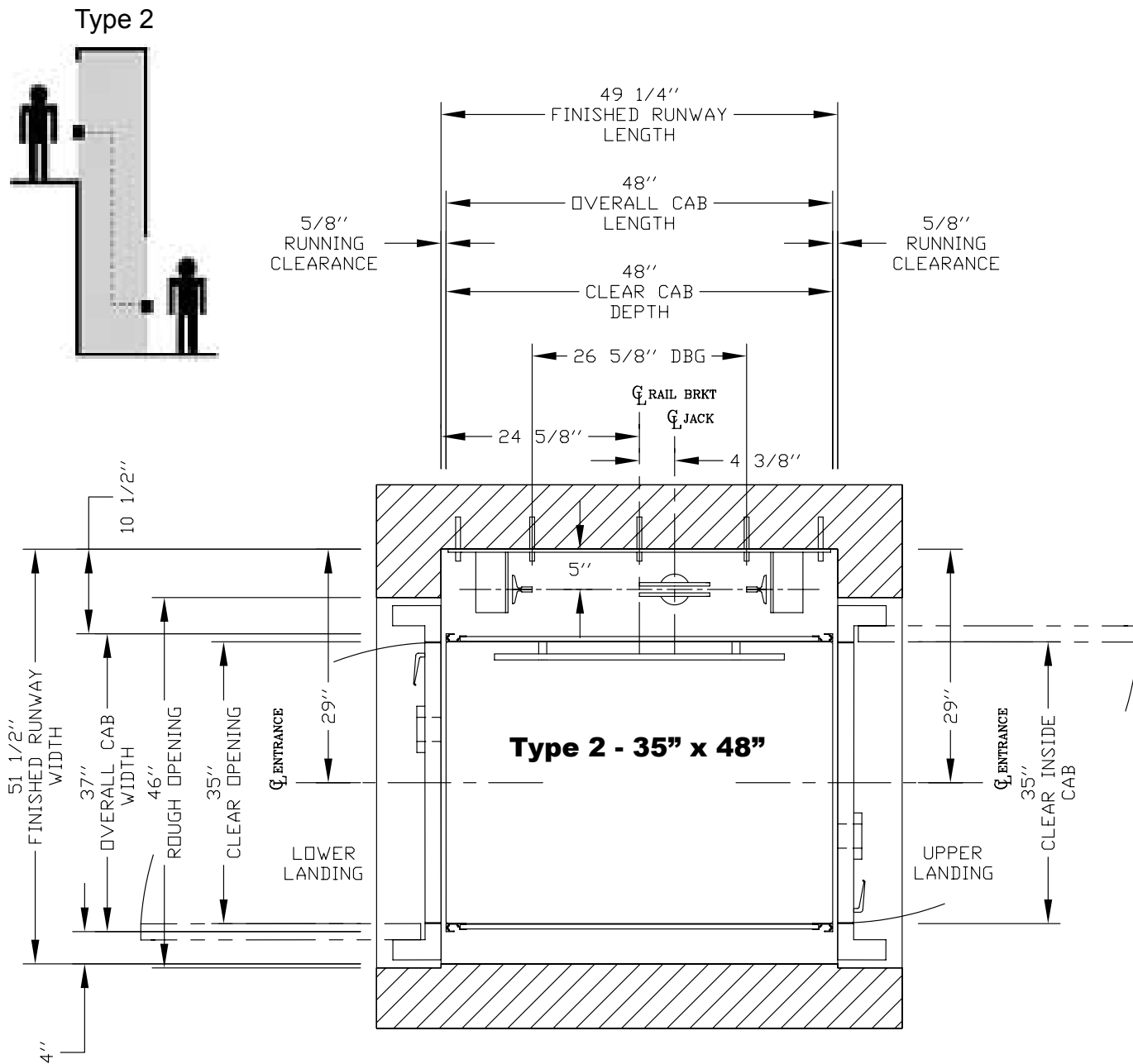

NOTE

Plan view drawing can be reversed for Right Hand applications.

PROLIFT SCL 35" X 54" TYPE 2 WALK THROUGH – ENTER/EXIT EITHER SIDE

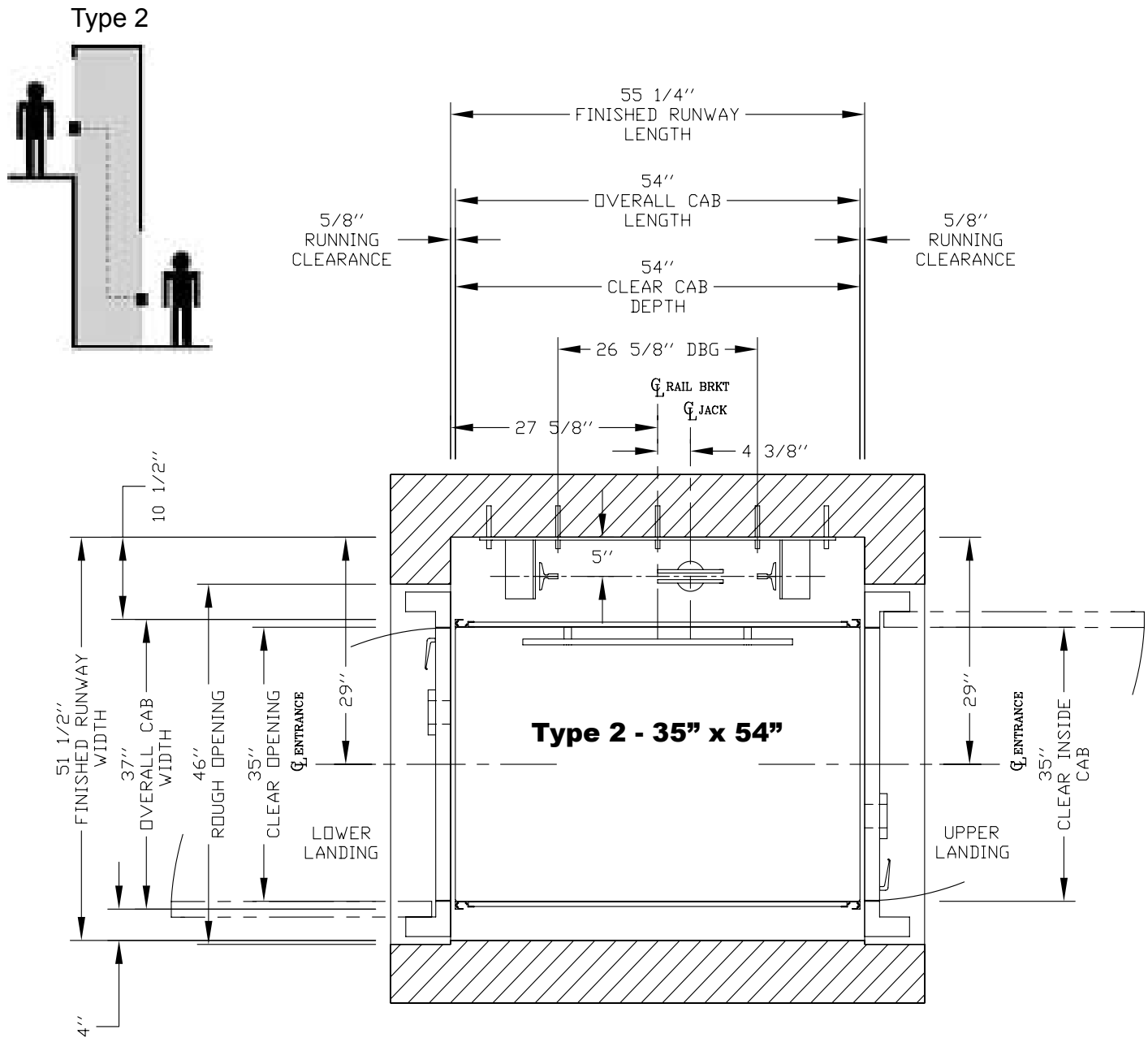

NOTE

Plan view drawing can be reversed for Right Hand applications.

PROLIFT SCL 35" X 60" TYPE 2 WALK THROUGH – ENTER/EXIT EITHER SIDE

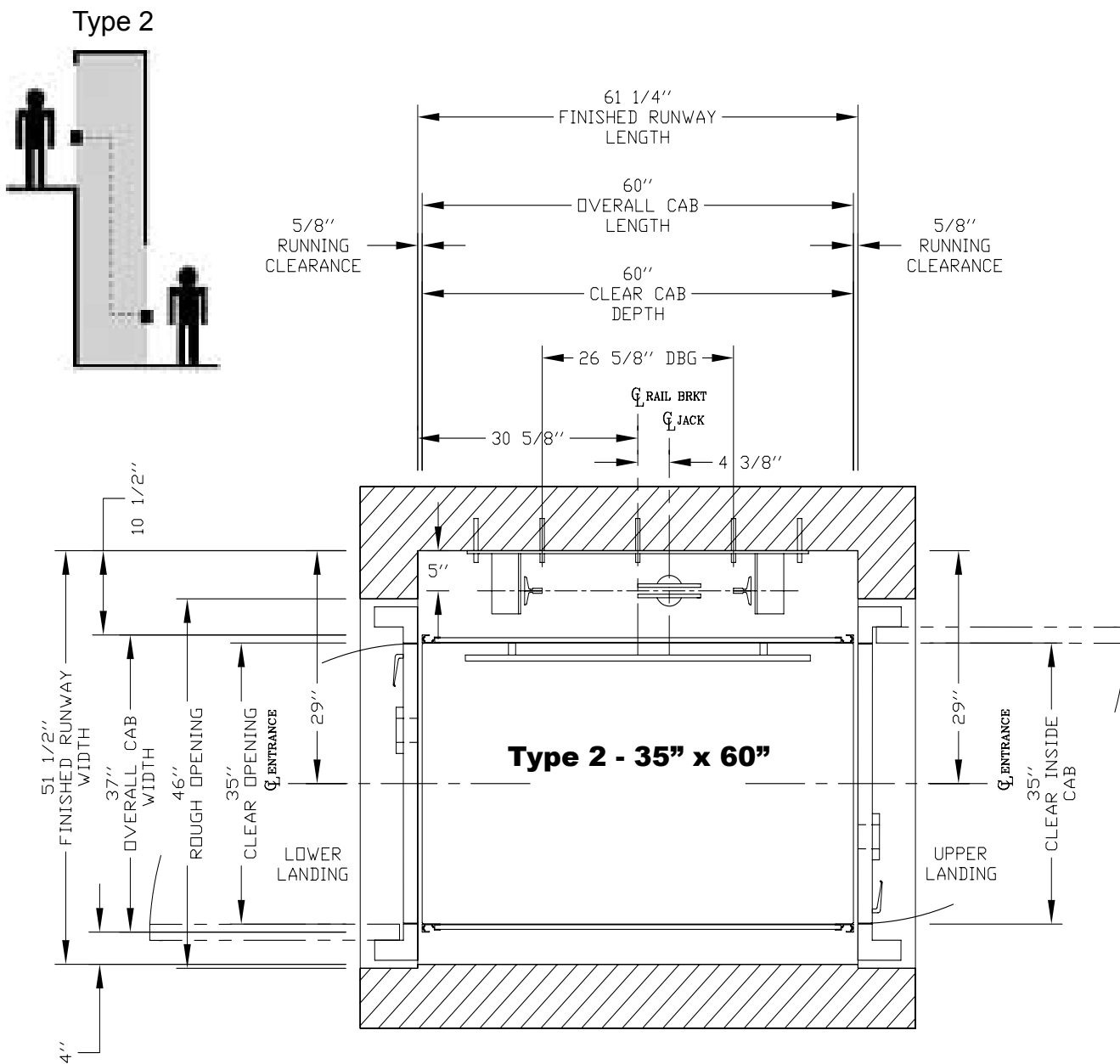

NOTE

Plan view drawing can be reversed for Right Hand applications.

PROLIFT SCL 35" X 48" TYPE 3 OR 4 - ENTER/EXIT FRONT OR SIDE

Type 3 or 4

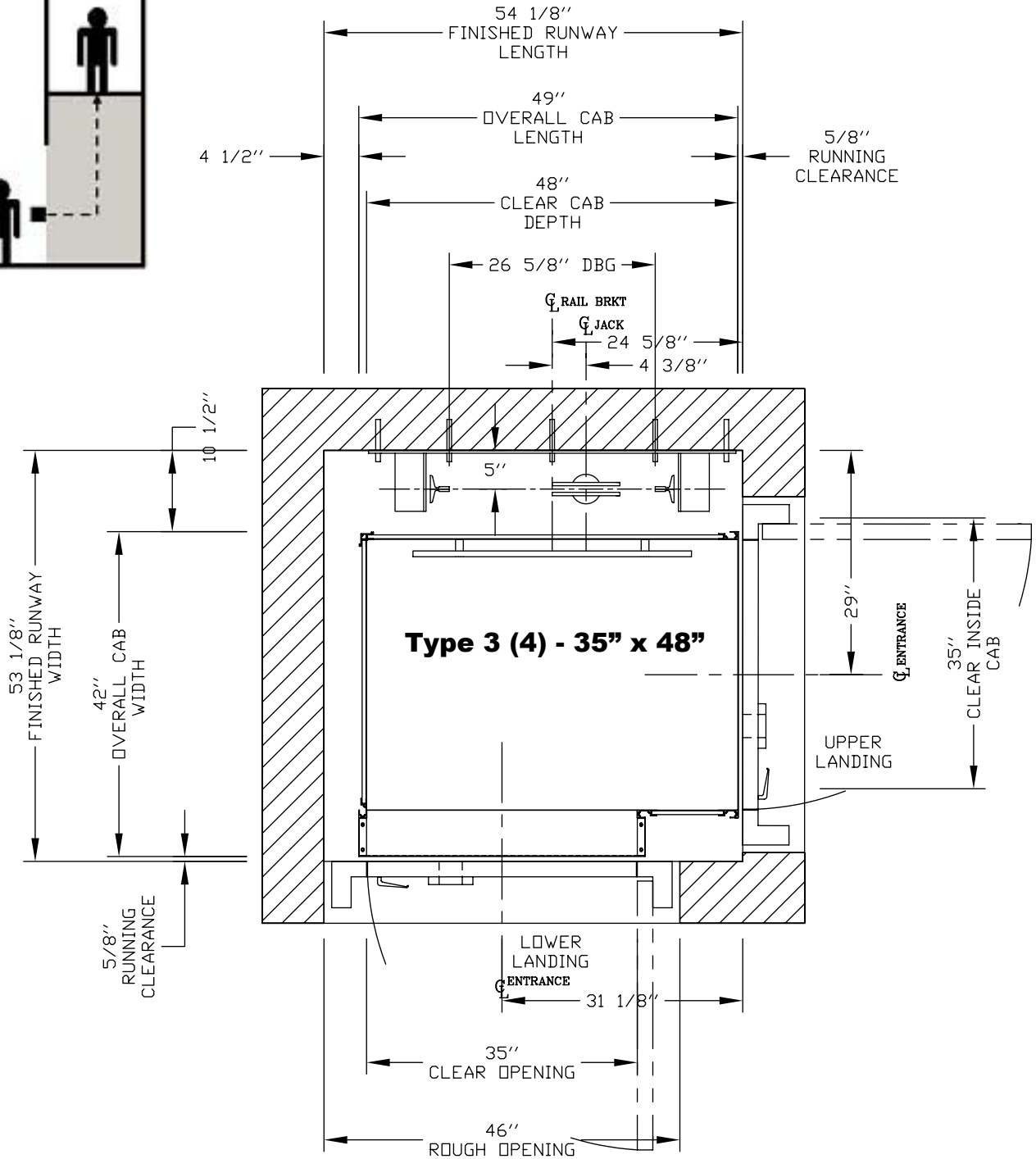
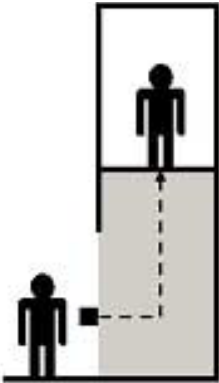

NOTE

Plan view drawing can be reversed for Type 4 applications.

PROLIFT SCL 35" X 54" TYPE 3 OR 4 - ENTER/EXIT FRONT OR SIDE

Type 3 or 4

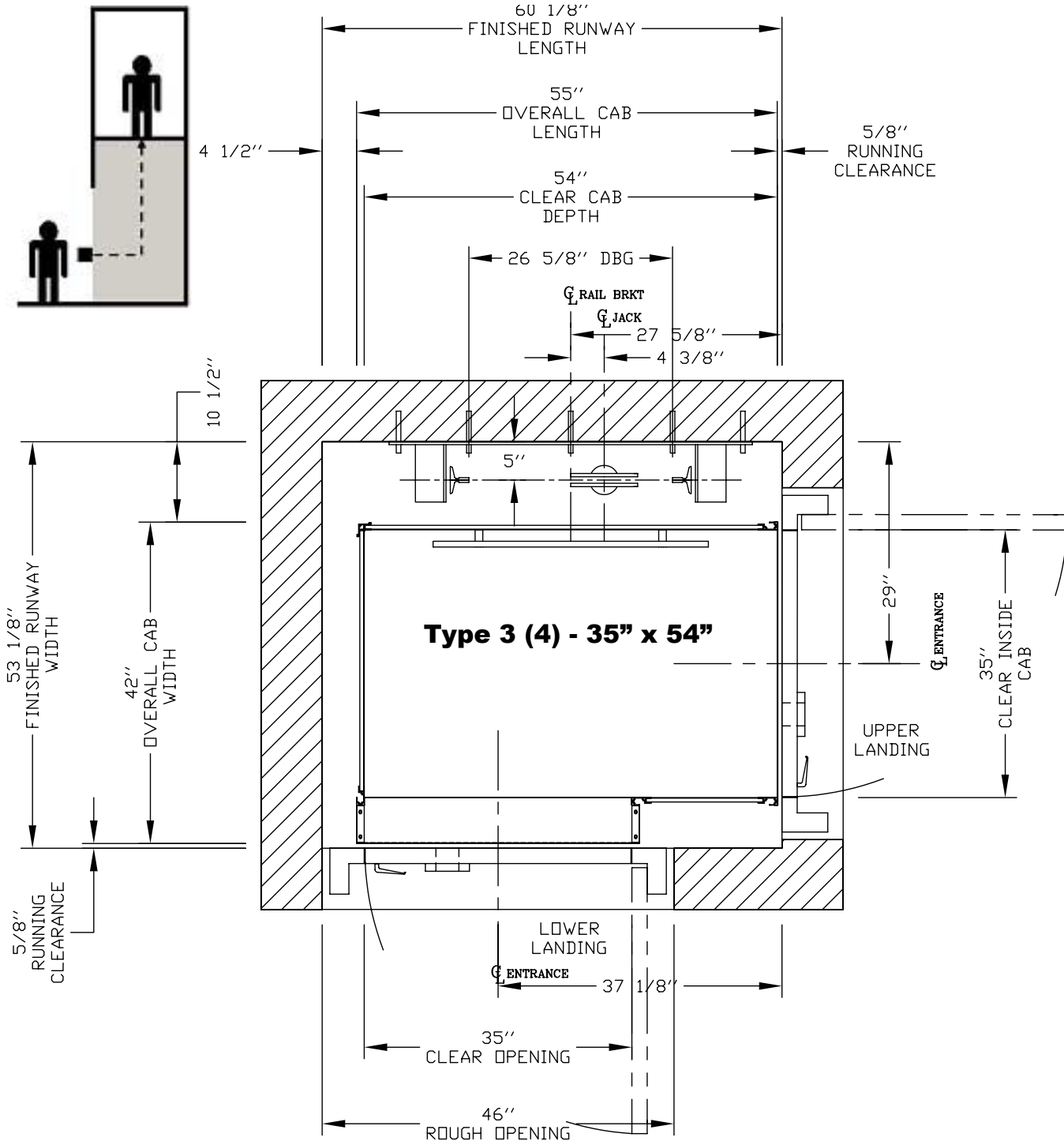

NOTE

Plan view drawing can be reversed for Type 4 applications.

PROLIFT SCL 35" X 60" TYPE 3 OR 4 - ENTER/EXIT FRONT OR SIDE

Type 3 or 4

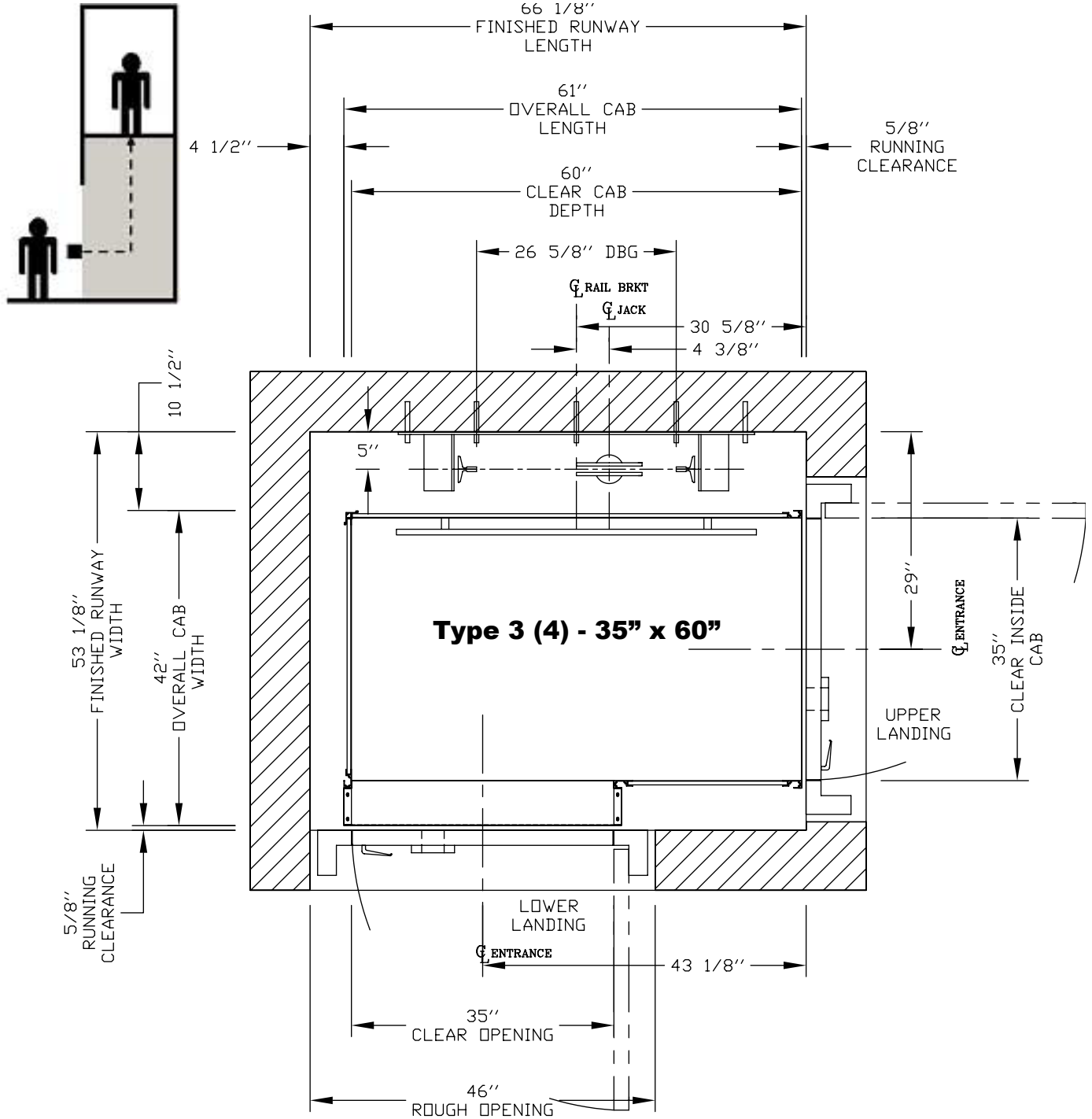

NOTE

Plan view drawing can be reversed for Type 4 applications.

Pro Auto and Pro Manual Door Specifications

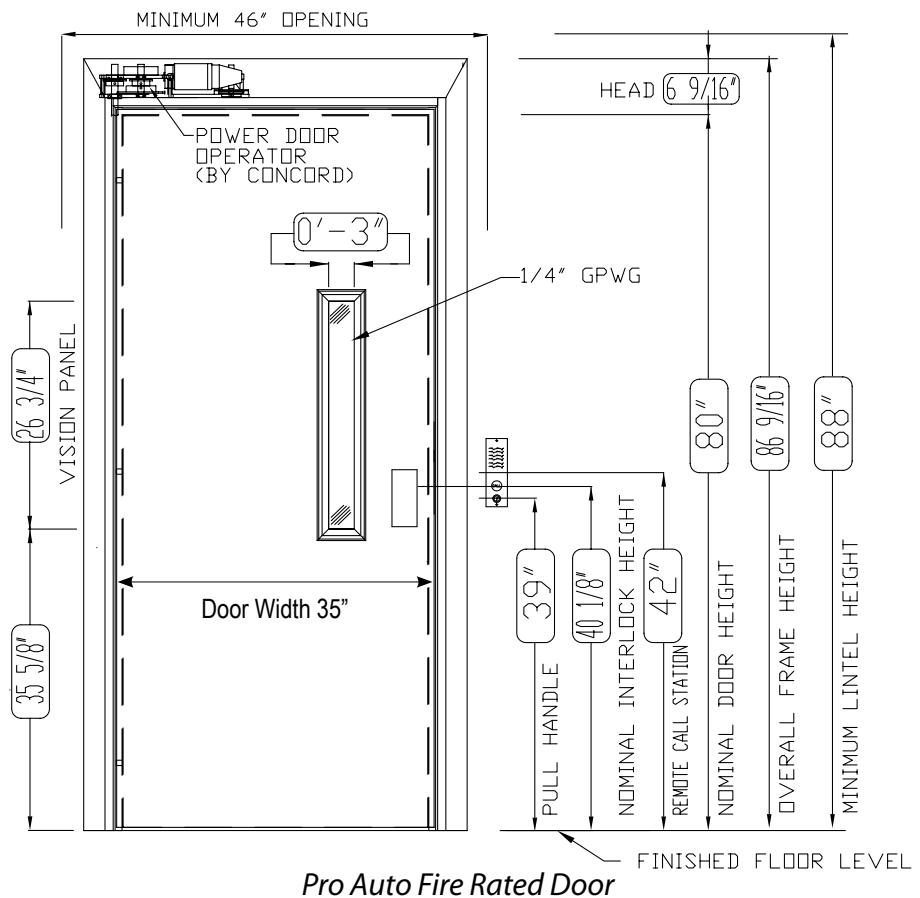
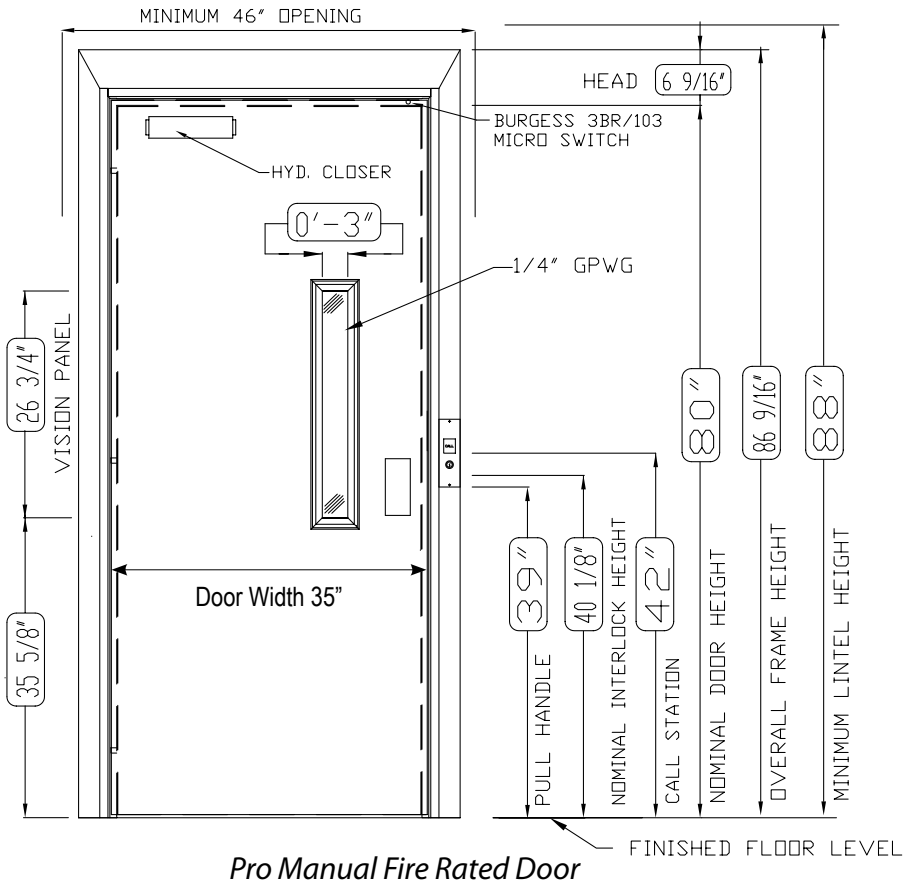

NOTE

1. See hoistway requirements for the location of the door centerline
2. Door panels and frame on Pro Doors are primed for painting.

Loads on Building

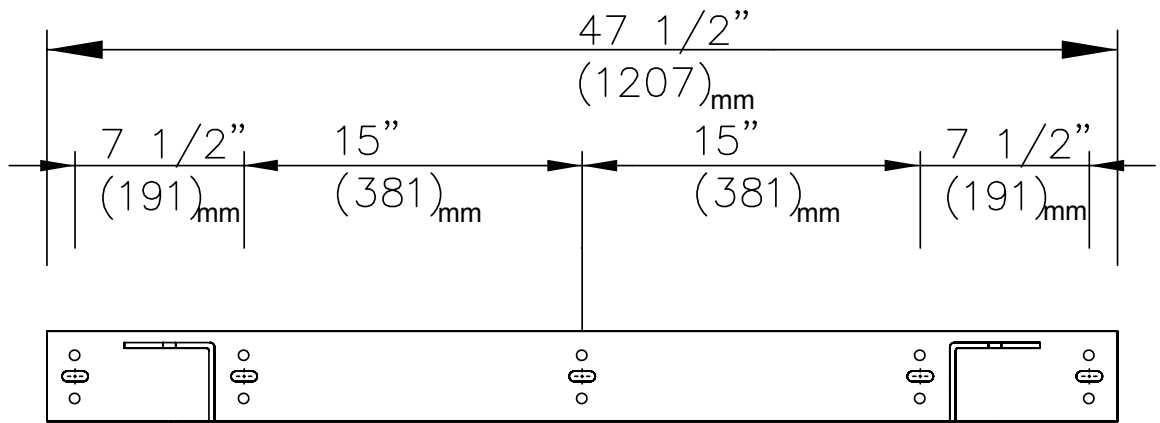
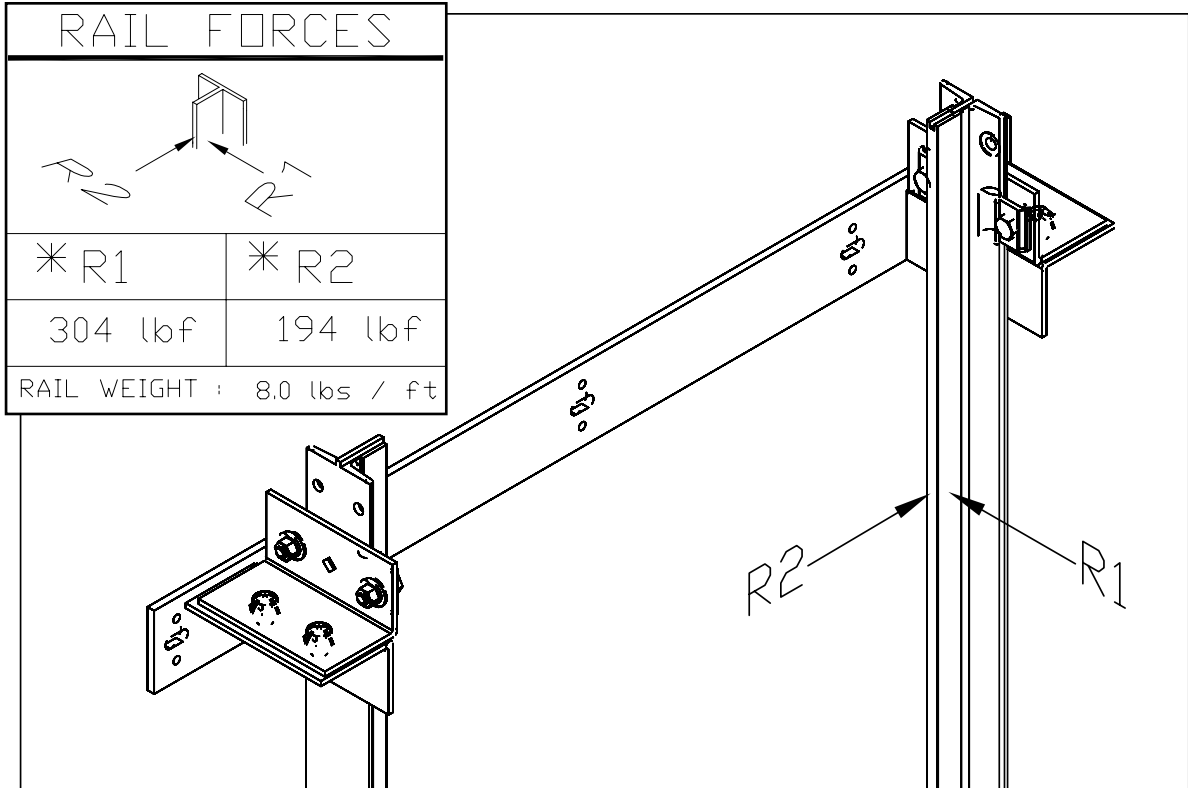

Rail Bracket Dimensions

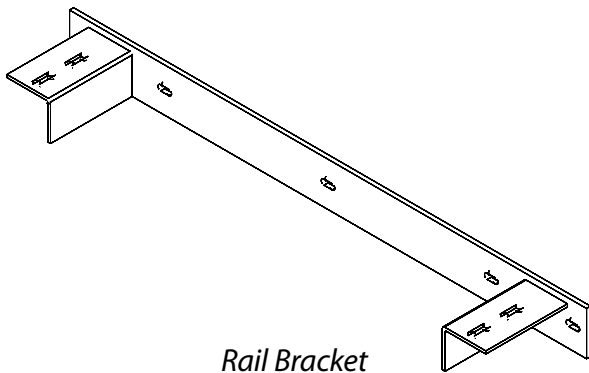

Rail Bracket

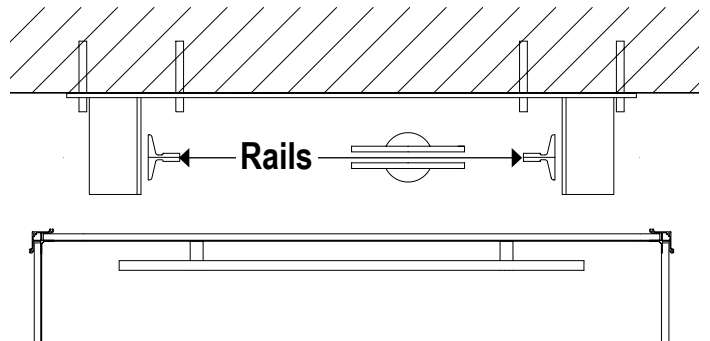

Support Wall Rail Orientation

Masonry Construction - Sectional View

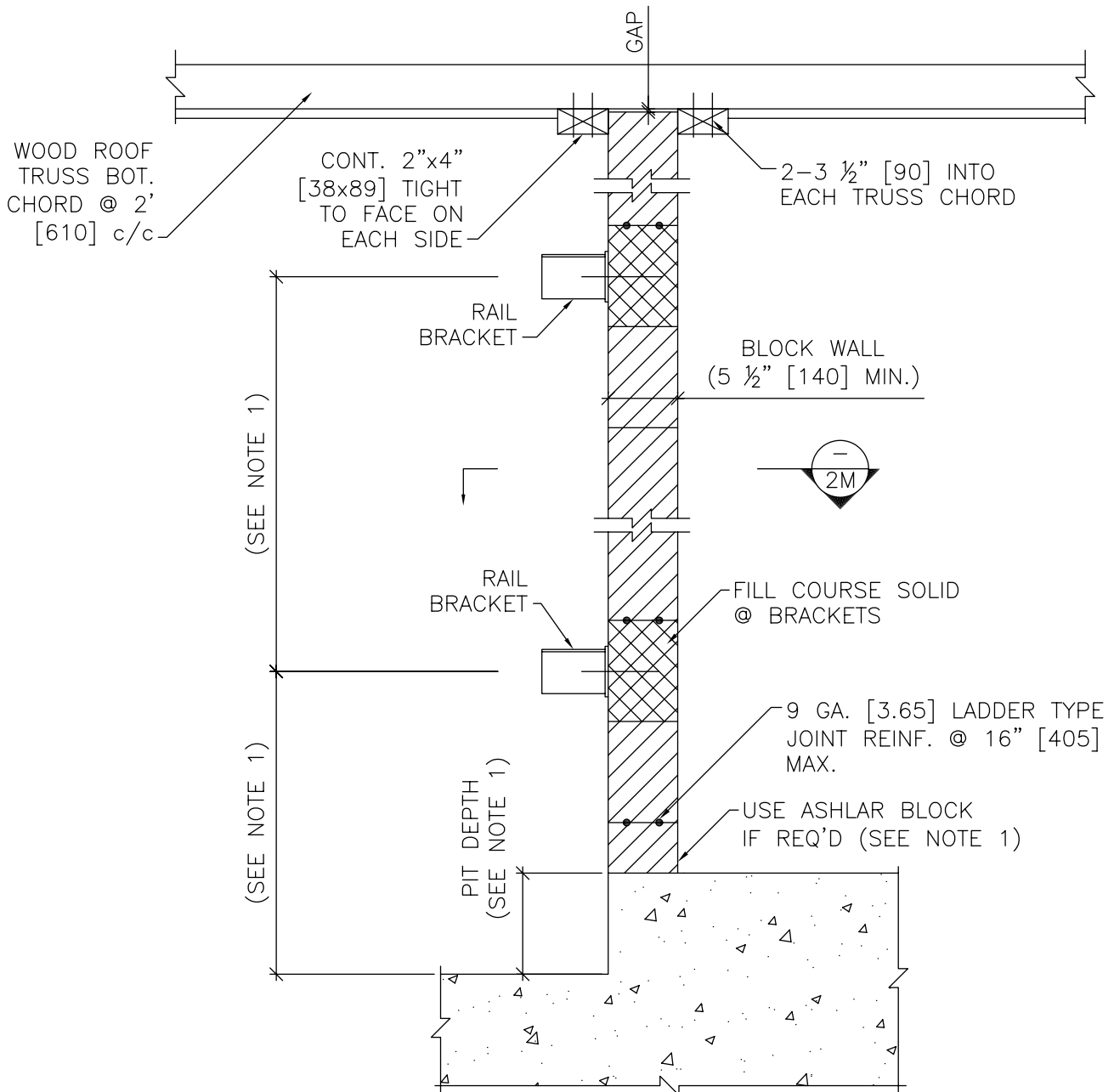

Masonry Construction - Plan View

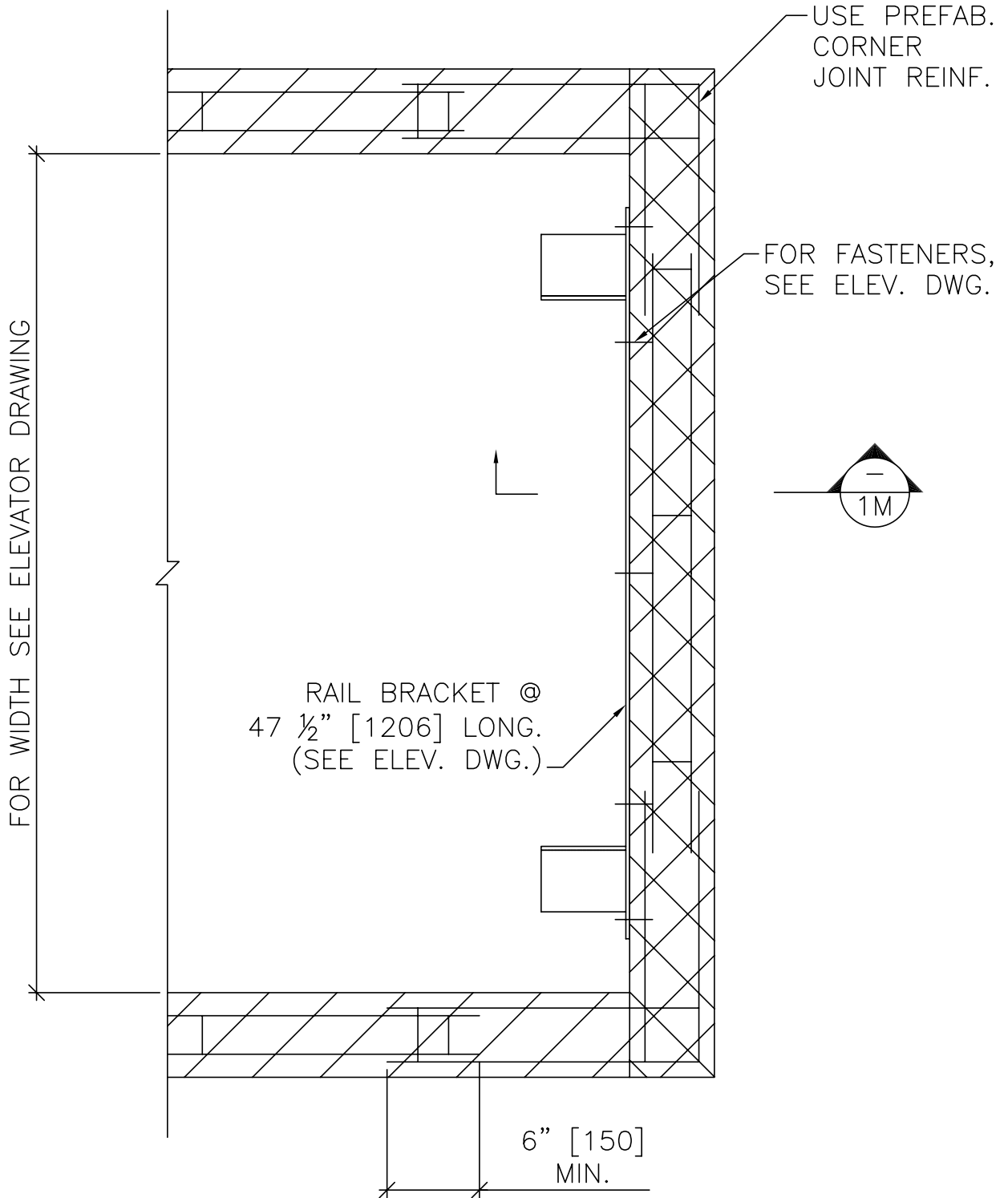

Wood Construction - Sectional View

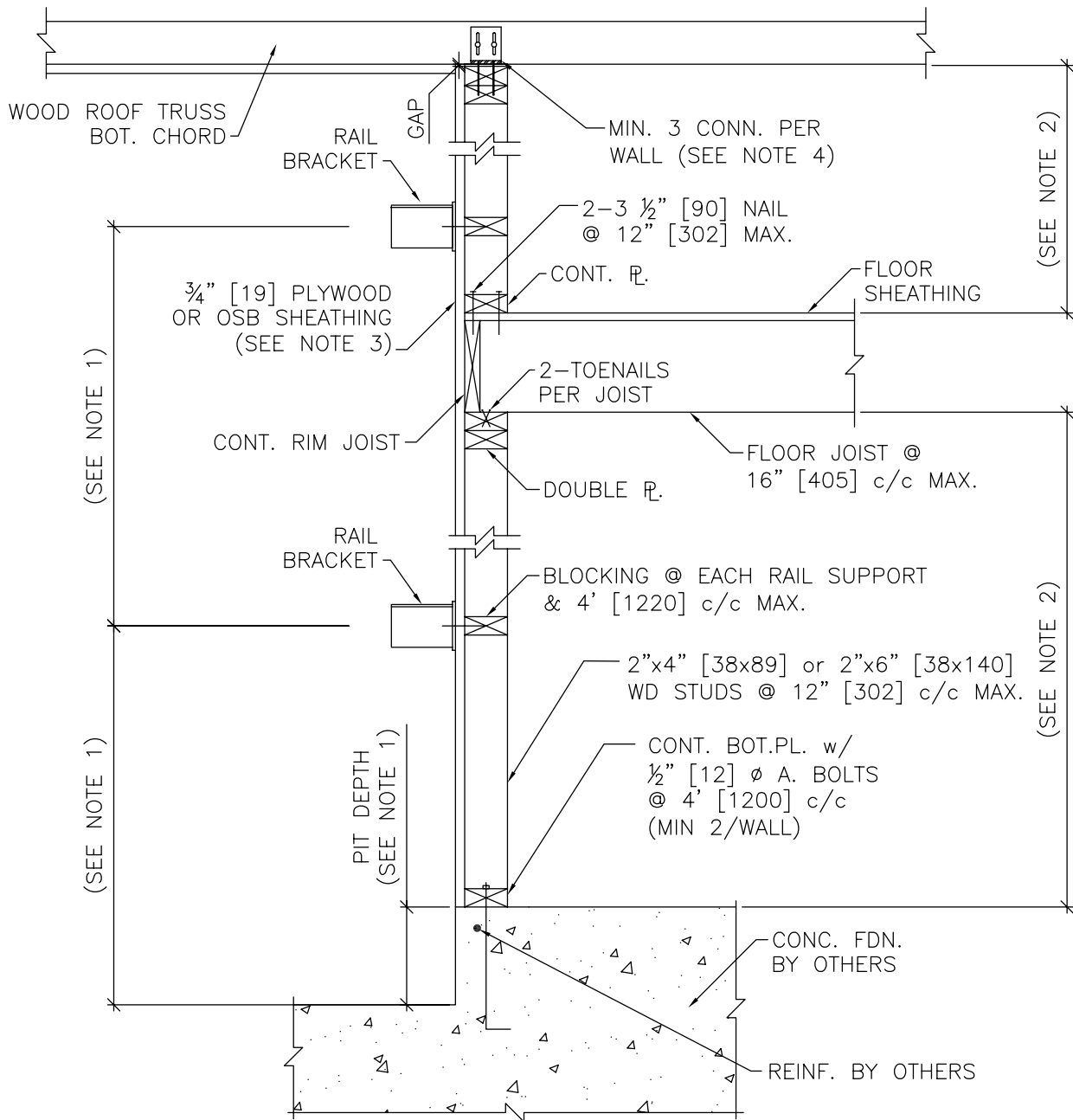

Wood Construction - Plan View

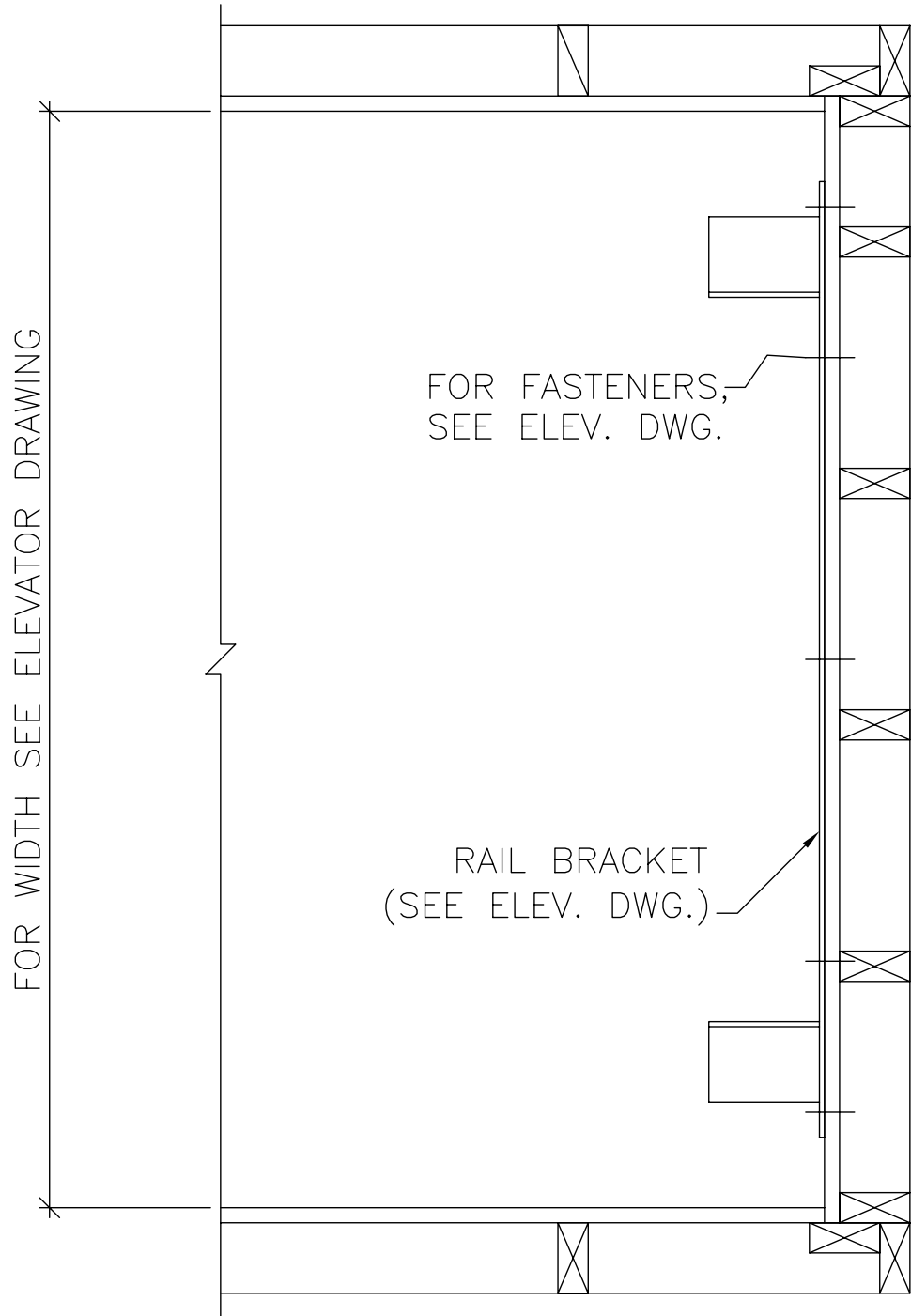

Pit Details

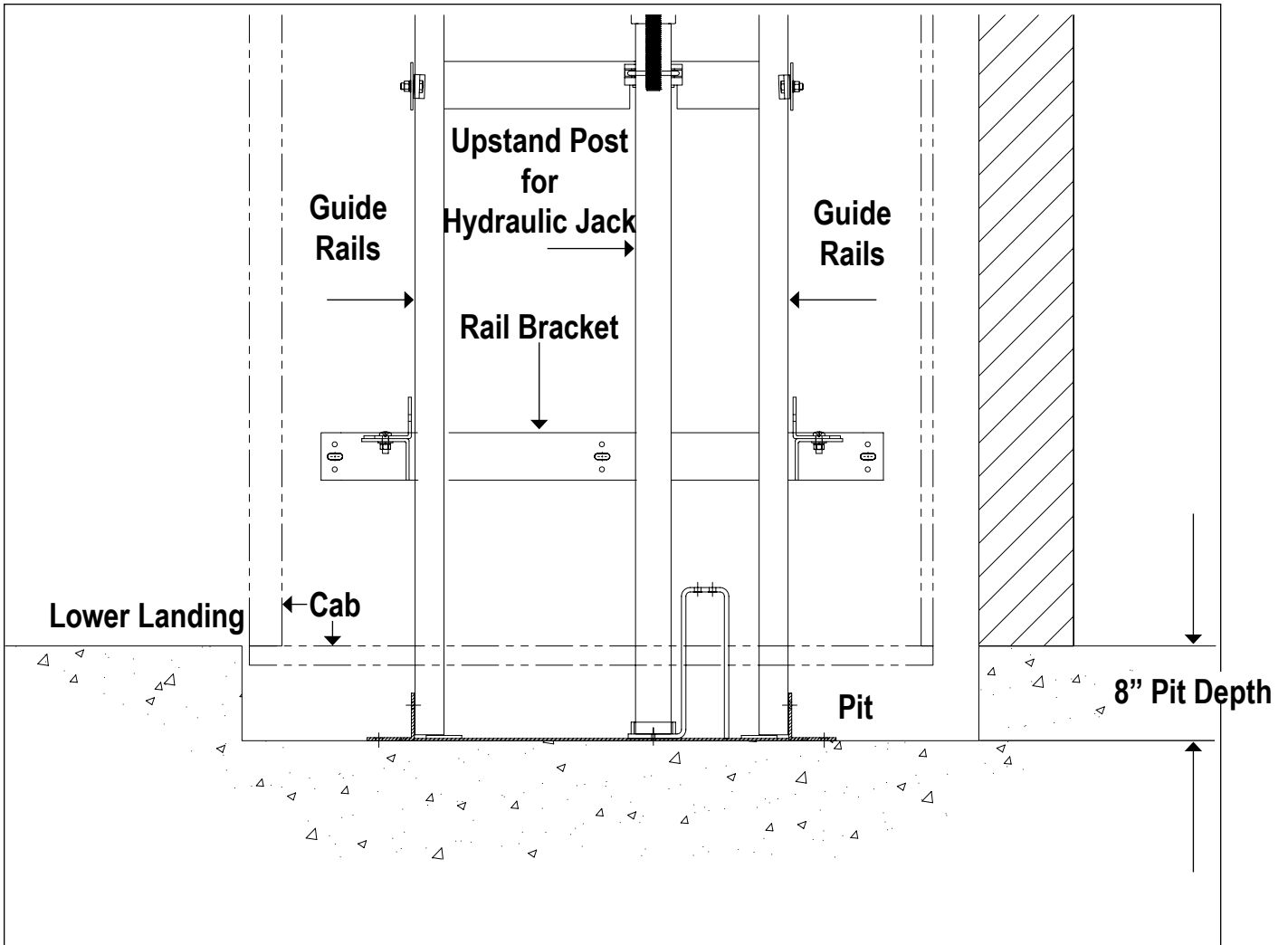

Overhead Clearance Details

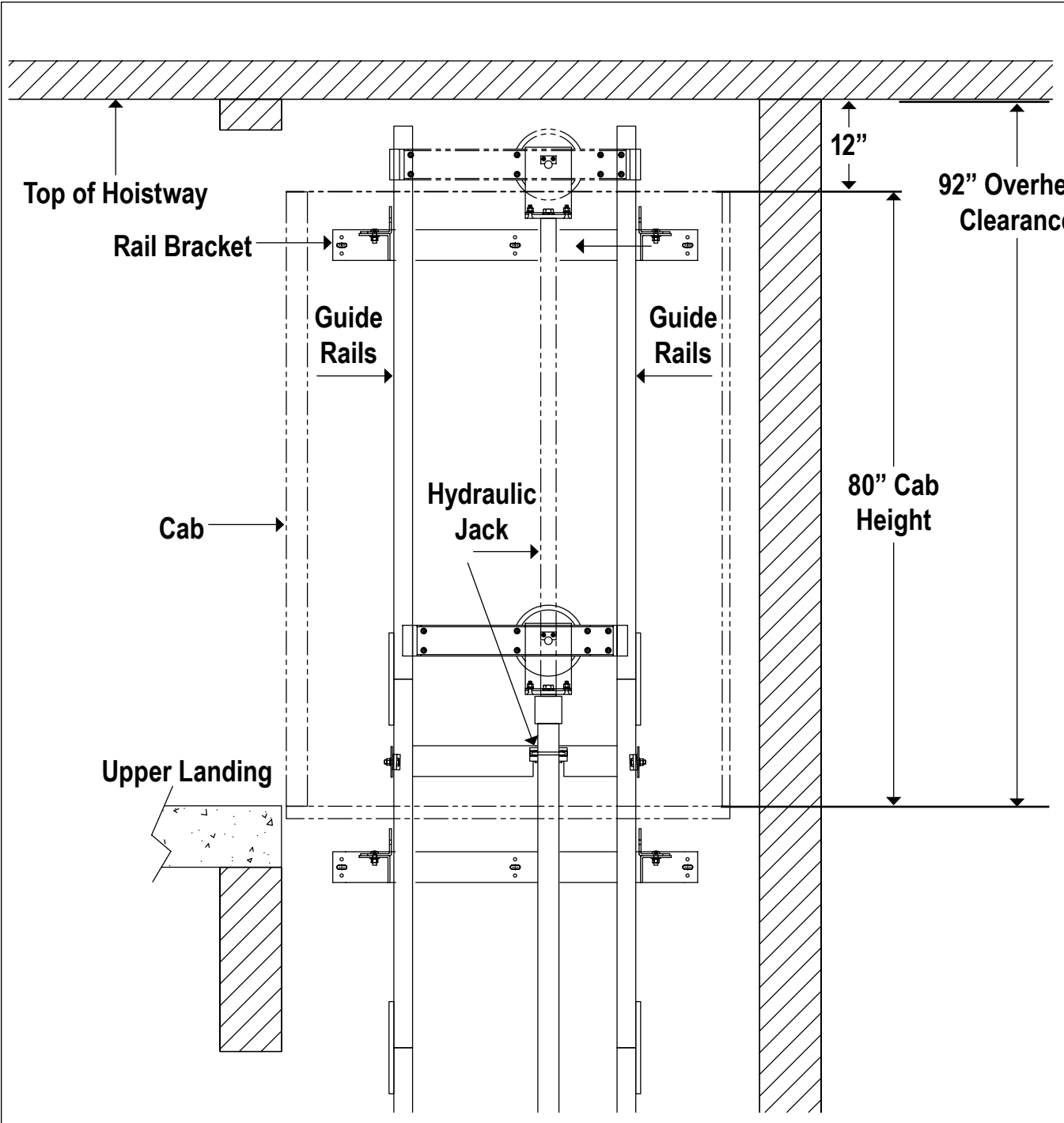

Suggested Wall Configuration for Wood Construction

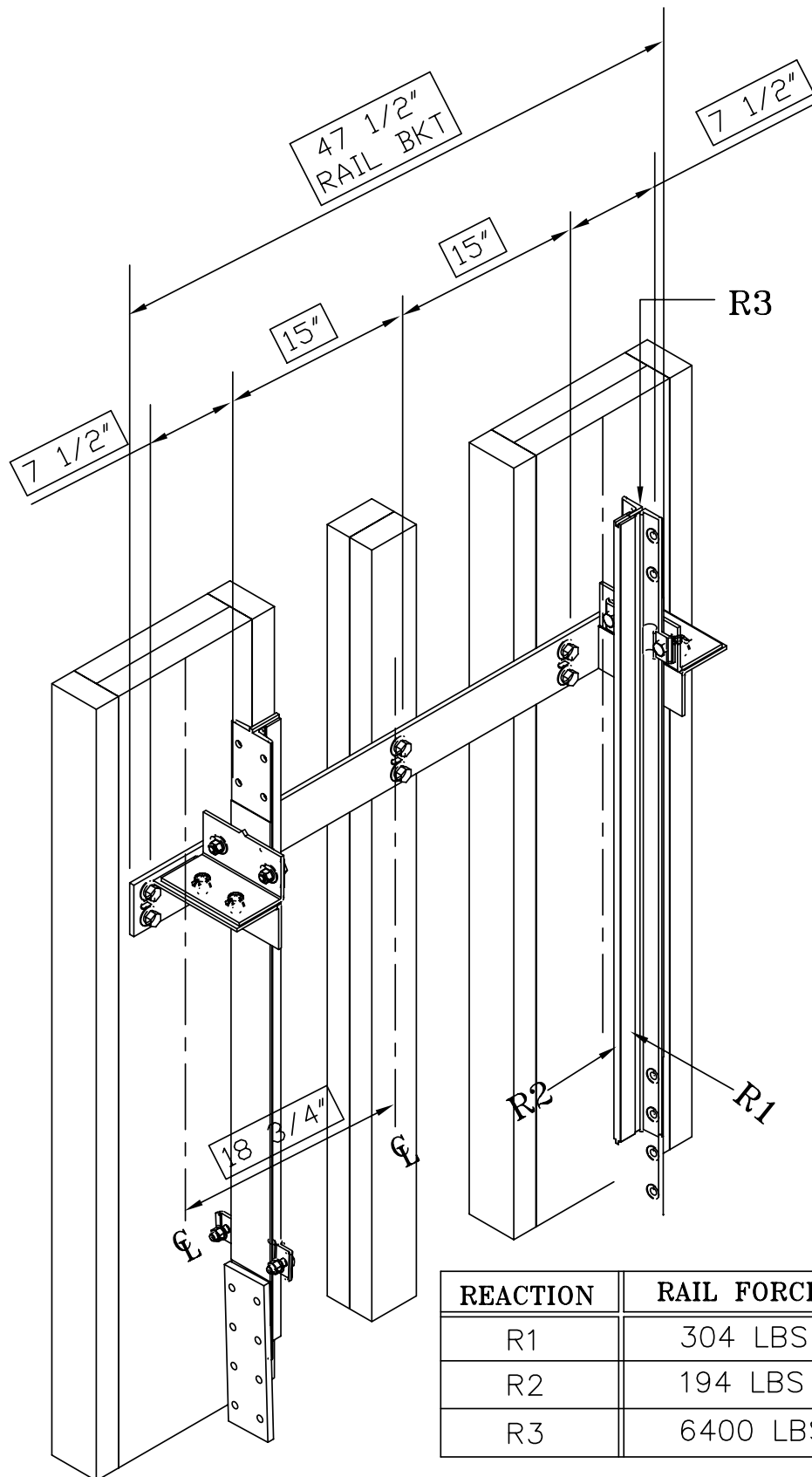

Suggested Wall Configuration for Wood Construction

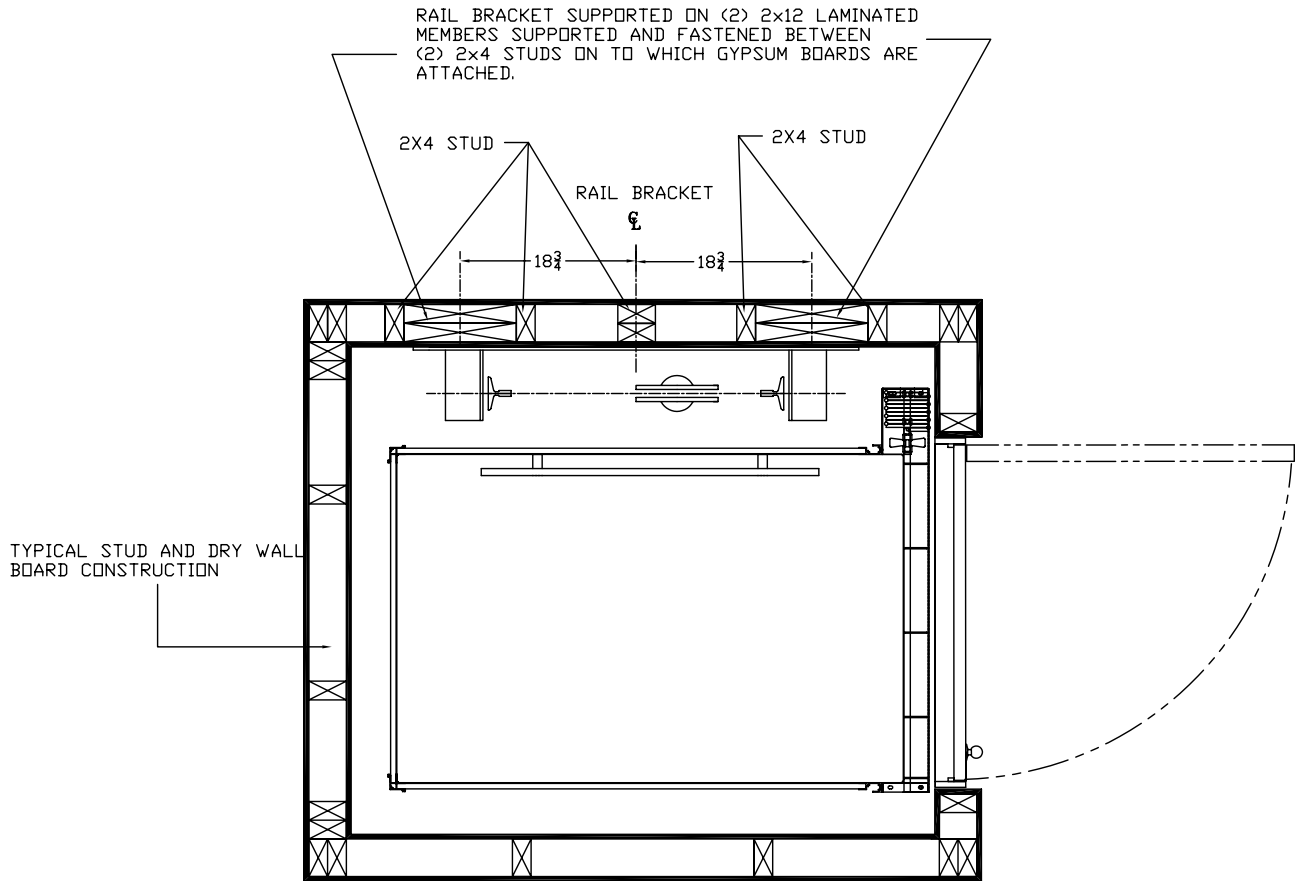

NOTE:

1. THIS DRAWING IS FOR REFERENCE ONLY. BUILDING STRUCTURAL ENGINEER TO ENSURE THAT THE BUILDING AND HOISTWAY WILL SAFELY SUPPORT ALL LOADS IMPOSED BY THE LIFT EQUIPMENT
2. FIRE RATING OF HOISTWAY IS SUBJECT TO LOCAL BUILDING CODES.

IMPORTANT

These drawings are for reference purposes only. The building structural engineer must ensure that the building and hoistway will support all loads imposed by the lift equipment. Fire rating of hoistway is subject to local building codes.

Rail Support Wall Specifications

Drawing Notes

- 1) See Lift Drawing for rail bracket spacing and pit depth.
- 2) Wall lateral support spacing:
 - for 2" x 4" studs, use 6 ft 10" (2090 mm) max.
 - for 2" x 6" studs, use 13 ft 6" (4120 mm) max.
- 3) Sheathing installation: install sheets vertically full width of shaft or min. centred on rail brackets.
- 4) Connectors to resist horizontal load but allow vertical movement.
For Wood, use 2" x 1/4" cap screw lag bolts.

General Specifications

- G1 The design and construction of all work is to conform to the local applicable building code.
- G2 Read these drawings in conjunction with all related architectural, mechanical, electrical, and lift drawings as well as any other contract documents.
- G3 The wall drawings have been prepared using engineering principles and the design loads that are applied by the lift rails to the wall. However, the details and member sizes and the attachments to the structure should not be construed as a complete design of the wall system. The contractor and/or the project engineer is responsible to evaluate the other loads that are applied to the wall from the floor or roof system and modify member sizes or connections as required by their analysis.
- G4 Do not scale the drawings.
- G5 See lift shop drawings for service loads (including dynamic effects) which are:
horizontal load parallel to the wall = 194 lb.
horizontal load perpendicular to the wall = 304 lb.
- G6 Wood: SPF NO 1/2 Mix
Concrete: 3000 psi (20 Mpa) @ 28 days. If exposed use 5% to 7% air content.
Anchor Bolts: ASTM A307
Mortar: Type "S"
Masonry Grout: 2100 psi (14 Mpa) High Slump
Masonry Block: 2100 psi (14 Mpa) on net area
- G7 Wall to be installed plumb and square within 1/8" (3 mm) of top and bottom of shaft.
- G8 Wall lateral support spacing (H) selected for maximum horizontal deflection of H/360 from rail loads.

Wood Construction

- W1 Separate wood from concrete with waterproof barrier or use pressure treated wood.
- W2 Bridging Maximum Spacing: Load Bearing or Shear walls – 4 ft c/c
- W3 Nail or screw sheathing at 6" c/c at edges and 12" c/c to other members.
Use 2.5" Standard Ardox nails or 2" #12 Screws.

Masonry Construction

- M1 All masonry construction to conform to applicable local standards
- M2 Reinforce lintel blocks with 2 m-15 m bottom bars unless noted.
- M3 Provide continuous ladder type joint reinforcement at 16" (400) c/c.

Prolift SCL Standard Notes

HOISTWAY

- The hoistway must be designed and built in accordance with all applicable codes (identified on the cover of this manual) and all state and local codes.
- Due to close running clearances owner/agent must ensure that hoistway and pit (where provided) are level, plumb and square and are in accordance with the dimensions on these drawings.

MINIMUM OVERHEAD CLEARANCE

- Owner/agent must ensure minimum overhead clearance is in compliance with codes.

CONSTRUCTION SITE

- Owner/agent to provide all masonry, carpentry and drywall work as required and shall patch and make good (including finish painting) all areas where walls/floors may require to be cut, drilled or altered in any way to permit the proper installation of the lift.

DIMENSIONS

- Contractor/customer to verify all dimensions and report any discrepancies to our office immediately.

STRUCTURAL

- Structural engineer to assure that building and shaft will safely support all loads imposed by the lift equipment. Refer to the tables on installation drawings for loads imposed by the equipment.
- Suitable lintels must be provided by owner/agent. Door frames are not designed to support overhead wall loads.

ELECTRICAL

- Power supply with a lockable fused disconnect and auxiliary contact to brake the battery feed, or circuit breakers with a 3-pole breaker for battery feed required in compliance with electrical code (contact your Savaria dealer or refer to the table below for OEM part numbers).
- Permanent power of 230V 1ph 40 amp or 208 Volt, 3ph, 30 amp must be supplied by others before installation.

Disconnect Switch Types & Accessories	Cutler Hammer	Federal Pioneer	Siemens
1 PHASE 3 H.P. Pump Unit			
2 Pole Solid Neutral 208 or 230V 1 PH	1HD221N	1322SN	ID321
Required Auxiliary Contact	DS16CP	E1K-1AEV-W94	MSSAK 116
Required Type "D" Fuse (Buss type "FRN" or equal)	2@20 amp	2@20 amp	2@20 amp
3 PHASE 3 H.P. Pump Unit			
3 Pole Solid Neutral 208V 3 PH	1HD321N	1332SN	ID321
Required Auxiliary Contact	DS16CP	E1K-1AEV-W94	MSSAK 116
Required Type "D" Fuse (Buss type "FRN" or equal)	3@15 amp	3@15 amp	3@15 amp
Cab Lighting			
1 Pole Solid Neutral 120V 1 PH	GP 111N	86211	CFN 211
Required Type "D" Fuse (Buss type "T" or equal)	1@15 amp	1@15 amp	1@15 amp

- Remote hall call (when supplied) to be installed by the owner/agent at 42" from landing floor.

ENTRANCES

- Entrance assemblies must be adjusted to align with platform and interlock equipment. Others to allow an adequate rough opening.
- Entrance assembly must be securely fastened to walls by elevator contractor.

Specifications for Part 5.3 Compliance

PART 1 - GENERAL

SCOPE

To furnish all labor, materials and equipment necessary or required to fully complete the installation of the commercial wheelchair platform lift as indicated on the Drawings and Specifications. This suggested specification is intended to cover the complete installation of the Concord Prolift SCL Commercial Wheelchair Lift design.

SYSTEM DESCRIPTION

The lift assembly shall consist of a power unit, car, guide system, 1:2 cable hydraulic lifting device, control system, signals and alarms, electrical wiring, and parts and accessories necessary to provide required performance, operation, code and safety requirements.

QUALITY ASSURANCE

1.3.1

The lift shall meet or exceed the applicable regulations of all governing agencies and be in conformance with the applicable sections of the most current edition of the following codes and standards:

- a) ASME A18.1-1999, A18.1a-2001, A18.1b-2001, A18.1-2003, A18.1-2005, A18.1-2008 Section 2, and CAN/CSA B355-M00.
- b) ICC/ANSI A117.1-1998 "Accessible and Usable Buildings and Facilities".
- c) NFPA 70-1999 "The National Electric Code" (NEC).
- d) ADAAG "Americans With Disabilities Act Accessibility Guidelines" (where applicable).
- e) CSA B44.1/ASME A17.5 "Elevator and Escalator Electrical Equipment"
- f) Local codes and regulations, as applicable.

1.3.2 REQUIREMENTS OF THE REGULATORY AGENCIES

- a) Fabricate and install work in compliance with all applicable jurisdictional authorities.
- b) File shop drawings and submissions to local authorities as the information is made available. Company pre-inspection and jurisdictional authority inspections and permits are to be made on a timely basis as required. Work will include all inspections and re-inspections that are required to ensure licenses are issued.

1.3.3 SUBCONTRACTOR QUALIFICATIONS

- a) Execute work of this specification only by a contractor/company who has adequate product and public liability insurance in excess of one million dollars.
- b) Skilled tradesmen must be employees of the contractor and perform the work on a timely basis. Employees must be trained by the manufacturer and be supervised by the lift contractor.

1.3.4 SUBSTITUTIONS

No substitutions will be considered unless written request for approval has been submitted by the bidder and received by the architect at least 10 days before the receipt of bids. Each such request shall include a complete description of the proposed substitute including drawings, test data, photographs, and any other information needed for consideration.

PART 2- PREPARATORY WORK BY OTHERS

2.1

The following preparatory work to accommodate/receive the lift is to be done by others.

2.1.1

Provide power unit machine room to meet applicable Codes and Standards.

2.1.2

Permanent power (220 Volt, Single Phase, 30 Amp or 208 Volt, 3 Phase, 30 Amp) to operate the lift to be provided to a Lockable Fused/Cartridge Type Disconnect Switch with auxiliary contact/switch for emergency battery lowering. Refer to architectural drawings for permanent power specifications and location of disconnects.

2.1.3

Provide 110-volt lighting supply and disconnect. Refer to architectural drawings for permanent power specifications and location of disconnects.

2.1.4

Provide an enclosed, plumb and square hoistway with smooth interior surfaces. Include for fascias or furring of hoistway interior where applicable.

2.1.5

Provide fire doors, frames, and door hardware.
Provide rough openings as per lift contractor's drawings.

2.1.6

Provide substantial, level pit floor slab to support loads indicated on lift contractor's shop drawings.

2.1.7

Provide adequate support for guide rail fastenings.

2.1.8

Provide pit water proofing to maintain a dry pit. Sump pump where required by authority having jurisdiction. (see lift contractor for location).

2.1.9

Provide 8" (203 mm) minimum pit.

2.1.10

Provide 92" (2337 mm) minimum overhead (distance from floor at upper level to underside of roof).

PART 3 - SUBMITTALS

3.1 SHOP DRAWINGS (presentation)

The shop drawings shall show a complete layout of the lift equipment detailing dimensions, clearances and location of machinery. Including the following:

- a) Drawings show the dimensions including plans, elevations, and sections to show equipment locations.
- b) Load and reaction drawings shall be provided by the lift manufacturer and detailed on drawings.

PART 4 – PRODUCT DATA

4.1 MANUFACTURER/PRODUCT

The lift shall be the SAVARIA Prolift SCL Standard Commercial Lift manufactured by Savaria Corporation.

Toll Free (800) 661-5112

Phone (905) 791-5555

Fax (905) 791-2222

Dealer Name _____

Number _____

Rated Load: (specify) 750 lbs (340 kg) or 1000 lbs (454 kg)

Nominal Speed: 30 fpm (0.15 mps)

Car Dimensions: (specify) 34" W X 48" D x 80" H or 35" W X

54" D x 80" H or 35" W x 60" D x 80" H

Operation: Constant Pressure

Power Supply:(specify) 230 Volt, 1 Phase, 40 Amps or 208 Volt, 3 Phase, 30 Amps

Travel Distance: (specify) 23 ft. (7 m) max _____

Levels Served: (specify) up to 5 _____

Number of Cab Openings: Two (2) Maximum

Lighting Supply: 115 Volt, 1 Phase, 60 Cycle, 15 Amps

Jack Type: 1:2 Cable Hydraulic

Pump Type: Submersible with Variable Speed Valve

Door Type:(specify) Pro-Manual, Pro-Auto Door, 2 Hr. UL/ULC Fire Rated Door

Leveling Device Type: Magnetic Floor Scanner

4.2 CAR ENCLOSURE

4.2.1 WALLS

1/2" (13 mm) Melamine or MDF panels and clear anodized aluminum trim.

4.2.2 CEILINGS

White Eggcrate with four (4) recessed incandescent down lights.

4.2.3 FLOOR

Steel Frame with Plywood sub-flooring recessed 1/2"

4.2.4 HANDRAIL

Stainless Steel handrail located on control panel side of cab

4.2.5 EMERGENCY OPERATION

The lift car shall be equipped with a battery-powered emergency lowering device and alarm that can be actuated on the failure of normal building power supply. Battery will be rechargeable type with an automatic recharging system.

4.2.6 EMERGENCY LIGHT

The car shall be equipped with an integral emergency light that will illuminate automatically in the event of a main power failure.

4.2.7 CAR OPERATING PANEL

Car operating panel shall consist of metal push buttons with halo lighting for each landing, an emergency stop button, an alarm button and a key switch. The key is removable in both the on and off position. All mounted on a #4 finished stainless steel panel.

4.2.8 DIGITAL FLOOR INDICATOR

Optional Digital floor indicator located in the control panel will display the location and direction of travel (floor number) of the lift in the shaft.

4.2.9 CAR LIGHTING

The car lighting shall consist of four (4) low voltage recessed incandescent down lights. The failure of one lamp shall not cause the remaining lamp to extinguish.

4.3 AUTOMATIC LIGHTS

Overhead lights in the car compartment shall turn ON automatically when the lift door is opened and will stay on while the lift is in use. The lift lights will shut off by a timer when the lift is not in use.

4.4 PRO AUTO SWING DOOR ENTRANCES

Complete entrance assembly to carry a fire label from UL/ULC certifying it has been tested and approved for minimum fire separation of two (2) hours. The landing entrances shall be supplied as an integral unit, pre-wired, zinc wipe coated and ready for installation at the site. Each integral landing entrance shall have an automatic swing type power door and have the following equipment included and mounted:

- a) Door vision panel approximately 3" x 26 3/4" (75 mm x 680 mm) of clear wired glass (or to the maximum permitted by the fire label) with aluminum finish frame
- b) Swing clear non-exposed heavy-duty stainless steel ball bearing hinges
- c) Interlock shall be provided with an electric contact, which will interrupt the power to the control mechanism if the door is in the OPEN position or if the door is not securely closed and locked. The interlock will prevent movement of the lift when the door is OPEN
- d) Door to be 35" x 80" (890 mm x 2030 mm) nominal, swing type.
- e) The door locking mechanism shall be of the concealed type with no visible beak
- f) Door shall be equipped with aluminum push plate, pull handle and interior kick plates
- g) Keyed hall call station with a metal push button with halo lighting and a stainless steel cover plate shall be mounted at each landing
- h) The automatic power door operator shall be concealed type, with accurate and adjustable speed control and pressure sensitivity
- i) Lock shall be time delayed electrically controlled for vandal resistant security
- j) Landing sill shall be aluminum checker plate

4.5 PLATFORM TOE GUARD

A platform toe guard shall be provided at each car entrance opening to extend below the car entrance opening for safety.

4.6 LEVELING DEVICE

- a) The lift shall be provided with a 2-way leveling device, which will maintain the car within 1/2" (13 mm) of the landing.
- b) Levelling device sensors shall be located in a position to be inaccessible to unauthorized persons.

4.7 HYDRAULIC POWER UNIT

- a) The pump and motor shall be the submersible type installed inside the oil tank.
- b) The controller shall be integrally mounted on the power unit frame and pre-wired and tested before shipment.
- c) Control circuitry to be located at the top of the oil tank.
- d) The power unit control valve shall be a variable speedproportional valve type that includes all hydraulic control valving inherently.

This valve shall incorporate the following features:

- (i) Up and down acceleration and deceleration speed adjustment for smooth starts and stops.
- (ii) Smooth stops at each landing shall be an inherent feature of the valve.
- (iii) Adjustable pressure relief valve.
- (iv) Manually operating 'DOWN' valve to lower lift in an emergency.
- (v) Pressure gauge indicating in P.S.I. and Bars.
- (vi) Gate valve to isolate cylinder from pump unit.
- (vii) Negative pressure switch.

4.8.1

The cylinder shall be constructed of steel pipe of a sufficient thickness and suitable safety margin. The top of the cylinder shall be equipped with a cylinder head with an internal guide ring and self-adjusting packing.

4.8.2

The plunger shall be constructed of a steel shaft of a proper diameter machined true and smooth. The plunger shall be provided with a stop electrically welded to the bottom to prevent the plunger from leaving the cylinder.

4.9 CABLE

Minimum of two 3/8" (10 mm) IWRC Galvanized Aircraft Cables.
Minimum breaking strength of 14,400 lbs. each.

4.10 SAFETY DEVICE

A "slack/broken cable" safety device shall be supplied which will stop and sustain the lift and its rated load, if either of the hoisting cables become slack or breaks. The safety device shall be resettable by the operation of the lift in the upward direction. A switch shall be mounted in such a position as to sense the operation of the safety device, and will open the safety circuit to the controller to prevent operation of the lift in either direction.

4.11 GUIDE YOKE

The 1:2 guide yoke/sheave arrangement shall be supplied with a sheave, guide shoes, roller bearings and adjustable cable guards. The sheave shall be finished with rounded grooves to fit the cables.

4.12 FINAL LIMIT SWITCH

The lift shall be equipped with a final limit switch to cut off all power to the lift if the upper normal terminal stopping devices fail.

4.13 GUIDE RAILS AND BRACKETS

- a) Steel 8lb/ft "T" guide rails and brackets shall be securely fastened to the building structure.
- b) Brackets shall securely hold the guides in a plumb and true position regardless of car loading.
- c) Guides shall be bolted through the hoistway enclosure with back-up plates, washers and nuts. Subject to architects' alterations and approval.

4.14 CAR SLING

- a) Car sling shall be fabricated from steel members with adequate bracing to support the platform and cab.
- b) The buffer-striking member on the underside of the car must stop the lift before the jack plunger reaches its down limit of travel.
- c) Guide shoes to be solid slipper type with polyurethane inserts.

4.15 WIRING

All wiring and electrical connections shall comply with applicable codes, insulated wiring shall have flame retardant and moisture proof outer covering and shall be run in conduit or electrical wireways. Traveling cables shall be flexible and suitably suspended to relieve strain.

Part 5 - EXECUTION

5.1 EXAMINATION

All site dimensions shall be taken to ensure that tolerances and clearances have been maintained and meet local regulations.

5.2 PREPARATION

Pre-inspect the construction and service requirements for "Work by Others". These requirements will be included in drawings, diagrams, engineering data sheets and special instructions before the work commences.



107 Alfred Kuehne Blvd.
Brampton, ON Canada L6T 4K3
Phone: 905-791-5555
Fax: 905-791-2222
Sales: 800-661-5112
www.savaria.com